

TECHNICAL SPECIFICATIONS

Fingers Quantity	2
Actuation System	Under Actuated
Actuators	One Per Finger Current
Actuators Sensors	Temperature Rotational encoder
Opening (Fingertip)	175 Mm
Min Object Diameter For Cylindrical Grip	45 Mm
Max Object Diameter For Cylindrical Grip	100 Mm
Min Object Diameter For	8 Mm
Total Weight	556 G
Gripping Force	25 N
Opening Or Closing Travel Time	1.2 Sec
Operating Temperature	-10°C to 40°C

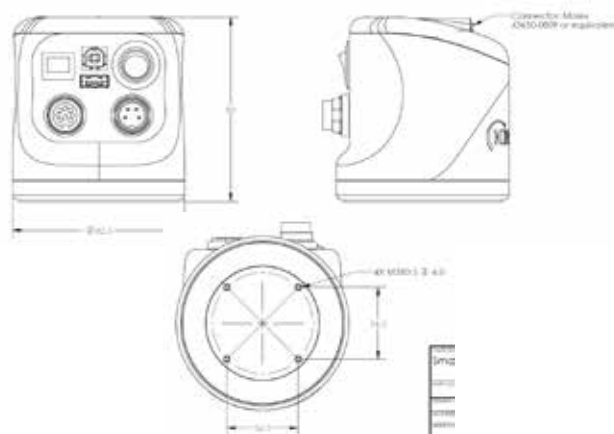

CONTROLLER

PORTS

Joystick	1 Mbps CANBUS
Power supply	18 to 29 VDC
USB 2.0 (API)	12 Mbps
Ethernet	Not Available
Control System Frequency	100 Hz (High Level API) 500 Hz (Low Level API)

CPU 360 MHz

SDK

APIs	High and low level
Compatibility	Windows, Linux Ubuntu & ROS
Port	USB 2.0
Programming languages	C++

POSITION CONTROL



TECHNICAL SPECIFICATIONS

Fingers Quantity	3
Actuation System	Under Actuated
Actuators	One Per Finger Current
Actuators Sensors	Temperature Rotational encoder
Opening (Fingertip)	175 Mm
Min Object Diameter For Cylindrical Grip	45 Mm
Max Object Diameter For Cylindrical Grip	100 Mm
Min Object Diameter For Object-on-the-ground Pinch	8 Mm
Total Weight	727 G
Gripping Force	
3 fingers	40 N
2 fingers	25 N
Opening Or Closing Travel Time	1.2 Sec
Operating Temperature	-10°C to 40°C

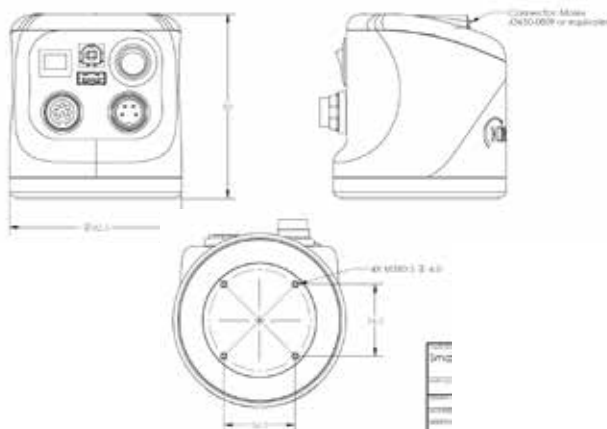

CONTROLLER

PORTS

Joystick	1 Mbps CANBUS
Power supply	18 to 29 VDC
USB 2.0 (API)	12 Mbps
Ethernet	Not Available

Control System Frequency	100 Hz (High Level API)
	500 Hz (Low Level API)

CPU	360 MHz
-----	---------

SDK

APIs	High and low level
Compatibility	Windows, Linux Ubuntu & ROS
Port	USB 2.0
Programming languages	C++

POSITION CONTROL

