

robosense® **LiDAR**

RS-Helios-1610

User Manual



Revision History

Issue	Modifications	Release Date	Edited by
1.0.0	Original issue	2022-08-31	PD

Terminologies

MSOP	Main data Stream Output Protocol
DIFOP	Device Info Output Protocol
FOV	Field Of View
PTP	Precision Time Protocol
NTP	Network Time Protocol
GPS	Global Positioning System
UTC	Universal Time Coordinated
Wave_mode	Echo flag
Protocol	Protocol version number, 00 represents old version, 01 represents the latest version
Temp	Sensor temperature information
Resv	Reserved data flag
Azimuth	LiDAR horizontal rotation angle
Timestamp	Time stamp which is used to record system time
Header	Frame header in protocol packet
Tail	Frame tail in protocol packet
Value	The decimal value obtained after conversion of the corresponding offset byte, using big-endian mode, with the high bit in the front and the low bit in the back

Content

1 Safety Notices	1
2 Helios Series Products	2
3 Product Appearance and Interface	3
3.1 Product Appearance	3
3.2 Aviation Plug and Pin Definition	3
3.3 Interface Box	4
4 Unboxing & Installation	6
4.1 Standard Package	6
4.2 Sensor Mounting	6
4.3 Quick Connection	8
5 Sensor Specifications and Features	10
5.1 Sensor Specification	10
5.1.1 Parameters	10
5.2 Point Cloud Display	12
5.2.1 Coordinate Mapping	12
5.3 Reflectivity	12
5.4 Laser Return Modes	13
5.4.1 Principle of Laser Return Modes	13
5.4.2 Return Mode Flag	14
5.5 Phase Locking	14
5.6 Time Synchronization	15
5.6.1 GPS Time Synchronization	15
5.6.2 The Use of GPS for Time Synchronization	15
5.6.3 PTP Time Synchronization	16
5.6.4 PTP wiring Method	17
6 Communication Protocol	17
6.1 MSOP and DIFOP	18
6.2 Main Data Stream Output Protocol (MSOP)	18
6.2.1 Header	18
6.2.2 Data Blocks	19
6.2.3 Tail	21
6.3 Device Info Output Protocol (DIFOP)	22
7 Vertical Angles and Precision Point Timing Calculation	24
7.1 Channel Number and Vertical Angle	24
7.2 Exact Point Timing Calculation	24
8 Troubleshooting	26
Appendix A Web Interface	28
A.1 Device Screen	28
A.2 Web Interface for Sensor Setting	28
A.3 Diagnostic Screen	31
A.4 System Screen	32
Appendix B Information Registers	34

B.1 Motor Speed (MOT_SPD)	34
B.2 Ethernet (ETH)	34
B.3 FOV Setting (FOV_SET)	35
B.4 Motor Phase Offset (MOT_PHASE)	35
B.5 Top Board Firmware Version (TOP_FRM)	35
B.6 Bottom Board Firmware Version(BOT_FRM)	36
B.7 Motor Firmware Version(MOT_FRM)	36
B.8 Software Version(SOF_FRM)	36
B.9 Corrected Vertical Angle(COR_VERT_ANG)	37
B.10 Corrected Horizontal Angle(COR_HOR_ANG)	38
B.11 Serial Number(SN)	39
B.12 Software Version (SOFTWARE_VER)	39
B.13 UTC Time (UTC_TIME)	39
B.14 STATUS (STATUS)	40
B.15 Fault Diagnosis (FALT_DIGS)	40
B.16 GPRMC Data Packet-ASCII Code Data Type	42
Appendix C RSView	43
C.1 Software Features	43
C.2 Install RSView	43
C.3 Set Up Network	44
C.4 Visualize Streaming Sensor Data	44
C.5 Capture Streaming Sensor Data to PCAP File	45
C.6 Replay PCAP File	45
C.7 Set RSView Data Port	48
Appendix D RS-Helios ROS&ROS2 Package	49
D.1 Install Software	49
D.2 Download & Compile RoboSense LiDAR Driver Package	49
D.3 Configure PC IP	50
D.4 Real Time Display	50
D.5 View Offline Data	51
Appendix E Mechanical Drawings	52
Appendix F Sensor Cleaning	53
F.1 Attention	53
F.2 Required Materials	53
F.3 Cleaning Method	53

1. Manufacturer Information

Suteng Innovation Technology Co., Ltd. (RoboSense)

Building 9, Block 2, Zhongguan Honghualing Industry Southern District, 1213 Liuxian Avenue,
Taoyuan Street, Nanshan District, Shenzhen, China Landline: 0755-86325830

Mobile Phone: +86 15338772453 (Marketing & Sales Cooperation)

Email: service@robosense.cn

Working hours from Monday to Friday 09:00-18:00 (GMT/UTC +8)

2 Disclaimer of Liability

This manual is protected by copyright. Any rights arising from this copyright are owned by RoboSense. Reproduction of this manual or part of the manual is only permitted within the legal scope of the copyright law. Without obtaining any authorization, this document shall not be abridged or translated. The trademarks mentioned in this document are the property of their respective owners. RoboSense reserves all rights.

3 Certifications



Note:

This manual is updated from time to time without prior notice, to get the latest version, please visit RoboSense company website to download or contact the RoboSense Technical Support or Sales.

1 Safety Notices

To avoid risks of accidents, damage to sensor or violating of your product warranty, please read and follow the instructions in this manual carefully before operating the product.

- Laser Safety

This product meets the following standards for laser products:

IEC 60825-1:2014;



- Please pay attention to the overheating sign on the LiDAR surface to avoid a hot LiDAR surface that may lead to sensor failure or undesirable consequences.



- Retain Instructions - The safety and operating instructions should be retained for future reference.
- Heed Warnings - All warnings on the product and in the operating instructions should be adhered to.
- Servicing – Except for what's described in this manual, the sensor has no field serviceable parts. For servicing, please contact RoboSense sales or the authorized distributors.

2 Helios Series Products

No.	Model	Number of Channels	FOV	Remark
1	RS-Helios-5515	32	-55°~+15°	Wide FOV
2	RS-Helios-1615	32	-16°~+15°	Uniform 1° Vertical Resolution
3	RS-Helios-1610	32	-16°~+10°	up to 0.5°
4	RS-Helios-16P	16	-15°~+15°	Uniform 2° Vertical Resolution

This manual is for the RS-Helios-1610 product.

3 Product Appearance and Interface

3.1 Product Appearance

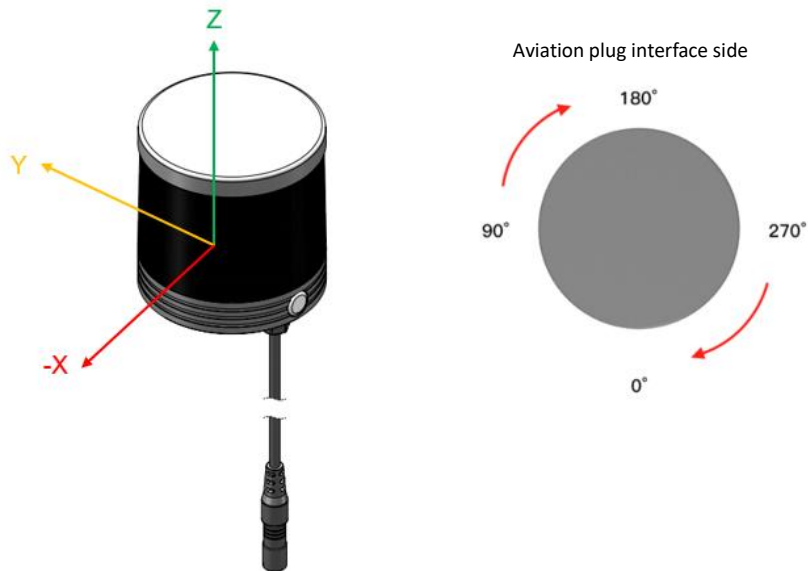
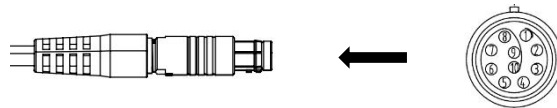

Figure 1 LiDAR Coordinate and Rotation Direction

3.2 Aviation Plug and Pin Definition

RS-Helios-1610 has an aviation plug attached to the bottom of the LiDAR, the definitions of the specific pins of the aviation plug are as shown in the table below:



Pin	Color	Function	Operating Voltage Range	Working Current	Other
1	Red	PWR	9~32V	1.2A	/
2	Black	PWR			
3	Gray	GND	/	1.2A	
4	Blue	GND			
5	Brown	GPS_PPS	3~15V	/	
6	White	GPS_GPRMC	-15V~+15V		

7	Purple	SYNC_OUT1	0~3.3V		Twisted Pair
8	Green	SYNC_OUT2			
9	Orange	TRD_N			
10	Yellow	TRD_P			

Figure 2 Definition of Pins of Aviation Plug

3.3 Interface Box

Your RS-Helios-1610 comes with an Interface Box, which has 2 LED lights and provides convenient connections to power, RJ45 Ethernet, and GPS. (The length of the integrated cable attached to the Interface Box of the aviation plug version LiDAR is 3 meters, for other cable lengths, please contact RoboSense technical support).

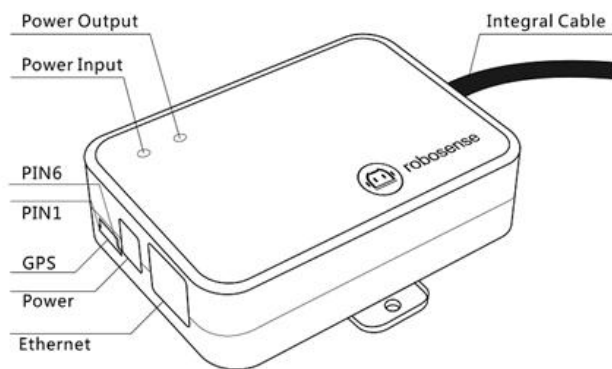

Figure 3 Definition of Interface Box Ports

Specifications of Interface Box ports:

Table 1 Interface Box Port Specification

No.	Port	Specification
1	Power Input	Standard DC 5.5-2.1 connector
2	Network	Standard RJ45 Ethernet connector
3	GPS timing	SH1.0-6P Female connector

3.3.1 Power

The power supply interface on the Interface Box is a standard DC 5.5-2.1 connector.

There are 2 LEDs in the Interface Box: when the power input is normal, the red LED lights up;

when the power output is normal, the green LED lights up. If the power indicator is dimmed, the Interface BOX may not work properly. Please check whether the power input is normal. If the power input is normal, the Interface BOX may be damaged. Please contact our technical support & sales.

3.3.2 RJ45 Ethernet Port

The network interface on the Interface Box follows the EIA/TIA568 standard.

3.3.3 GPS Time Synchronization

RS-Helios-1610 uses GPS for Time Synchronization: the GPS REC receives GPS UART standard input; GPS PULSE receives GPS PPS information input.

The definitions of pins of the GPS port are detailed in the figure below:

Table 2 GPS Port Definition

Pin No.	Function
1	GPS_PPS
2	+5V
3	GND
4	GPS_GPRMC
5	GND
6	SYNC_OUT1

Note: When the "ground" of RS-Helios-1610 is connected to an external system, the negative polarity ("ground") of the external system and the "ground" of the GPS system must share a non-isolated common ground.

4 Unboxing & Installation

4.1 Standard Package

The table below lists the contents of a standard RS-Helios-1610 package from the factory.

Table 3 Standard Factory Package of the RS-Helios-1610

No.	Contents	SPEC/QTY
1	LiDAR	RS-Helios-1610*1
2	Interface Box	3M *1
3	Power Adapter	DC12Vx3.34A/40W *1
4	Power Cable	1.2M *1
5	Ethernet Cable	1.5M *1
6	Screw Pack	M3X8 *4, M3X12 *4

Note: There might be variants of the sensor and accessories that you are going to purchase or interested in, please contact RoboSense Sales for details.

4.2 Sensor Mounting

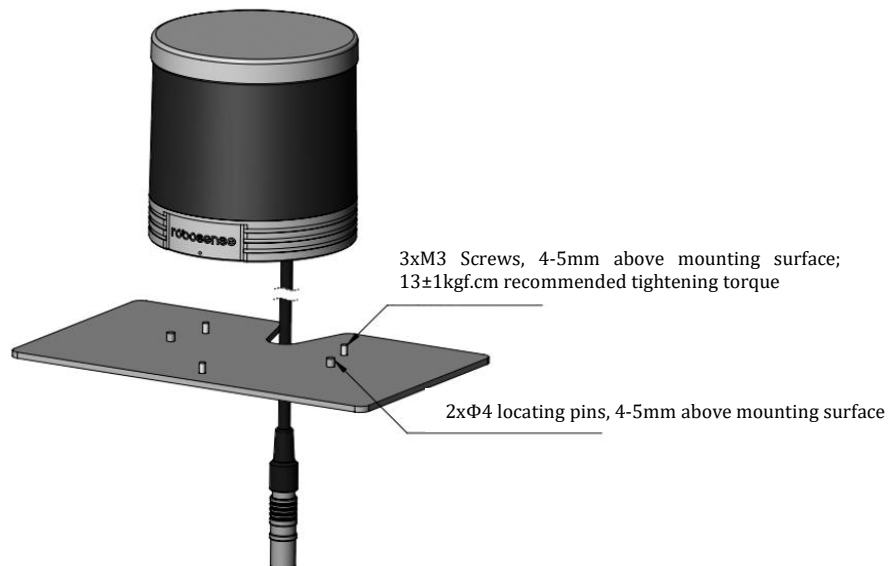

Figure 4 LiDAR Mounting Details

➤ Screw Specifications

GB/T70.1, M3x12, hexagon socket head, material SCM435, electroplated trivalent chromium

black zinc, grade 10.9, with drop resistance coating.

GB/T70.1, M3x8, hexagon socket head, material SCM435, electroplated trivalent chromium black zinc, grade 10.9, with drop resistance coating.

➤ Mounting Requirements

- 1) The mounting surface should be as flat as possible with the flatness be better than 0.05mm;
- 2) Use 3xM3 mounting screws to fix the LiDAR on the mounting surface, the screw should be 4~5mm above the mounting surface, the recommended tightening torque is $13\pm 1\text{kgf.cm}$;
- 3) Use 2x $\Phi 4$ locating pins to locate the LiDAR on the mounting surface, the pin should be 4~5mm above the mounting surface.

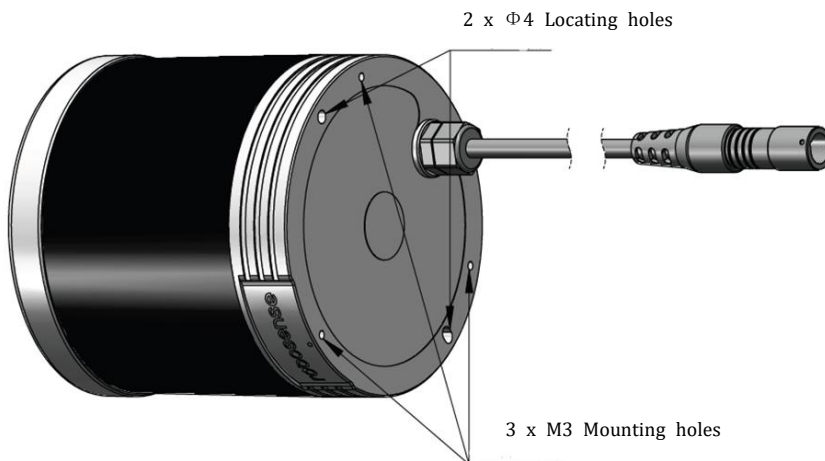

Figure 5 LiDAR Mounting Holes & Locating Holes Diagram

➤ Mounting Bracket Rigidity Requirements

The mounting bracket where the LiDAR is attached to should be rigid enough to ensure LiDAR in a stable operating state under various working conditions. Therefore, it is required that the first-order modal frequency of the LiDAR and the mounting bracket should be greater than 50Hz, and avoiding frequency range of 100~110Hz and 280-290Hz;

The LiDAR will be subjected to various random vibrations, mechanical shocks and other operating conditions during use. Under these conditions, the bracket needs to be strong enough to bear a relatively large load.

The following situations should be avoided when mounting the LiDAR:

- 1) The mounting surface of the LiDAR should be flat and uneven surfaces should be avoided.
- 2) The precise locator pins on the mounting base should strictly follow the dimensions of the

locator holes at the bottom of the LiDAR, and the height of the locator pin should not be higher than 4mm. We recommend using aluminum alloy for the mounting base material, which facilitates heat dissipating of the LiDAR during operating.

- 3) If there are contact mounting surfaces on the top and bottom of the LiDAR, please ensure that the distance between the mounting surfaces is greater than the height of the LiDAR to avoid squeezing the LiDAR.
- 4) When connecting cables of the LiDAR, make sure not to pull the cable too tightly, and keep the cables in a slack state.

4.3 Quick Connection

Users are allowed to configure the network settings of the RS-Helios-1610, which is set at the factory with default IP and port numbers, as shown in the table below:

Table 4 Factory Default Network Configuration

	IP Address	MSOP Port No.	DIFOP Port No.
RS-Helios-1610	192.168.1.200	6699	7788
Computer	192.168.1.102		

To establish communication between the LiDAR and computer, it's required to set the computer's IP address to the same network segment as the LiDAR, for example 192.168.1.x (the value of x could be from 1 to 254), and the subnet mask to 255.255.255.0. If you don't know the network configuration of the LiDAR, please connect the LiDAR to computer and use wireshark to capture the LiDAR data packets to analyze.

The wiring diagram of the Interface Box connection is as shown in the figure below:

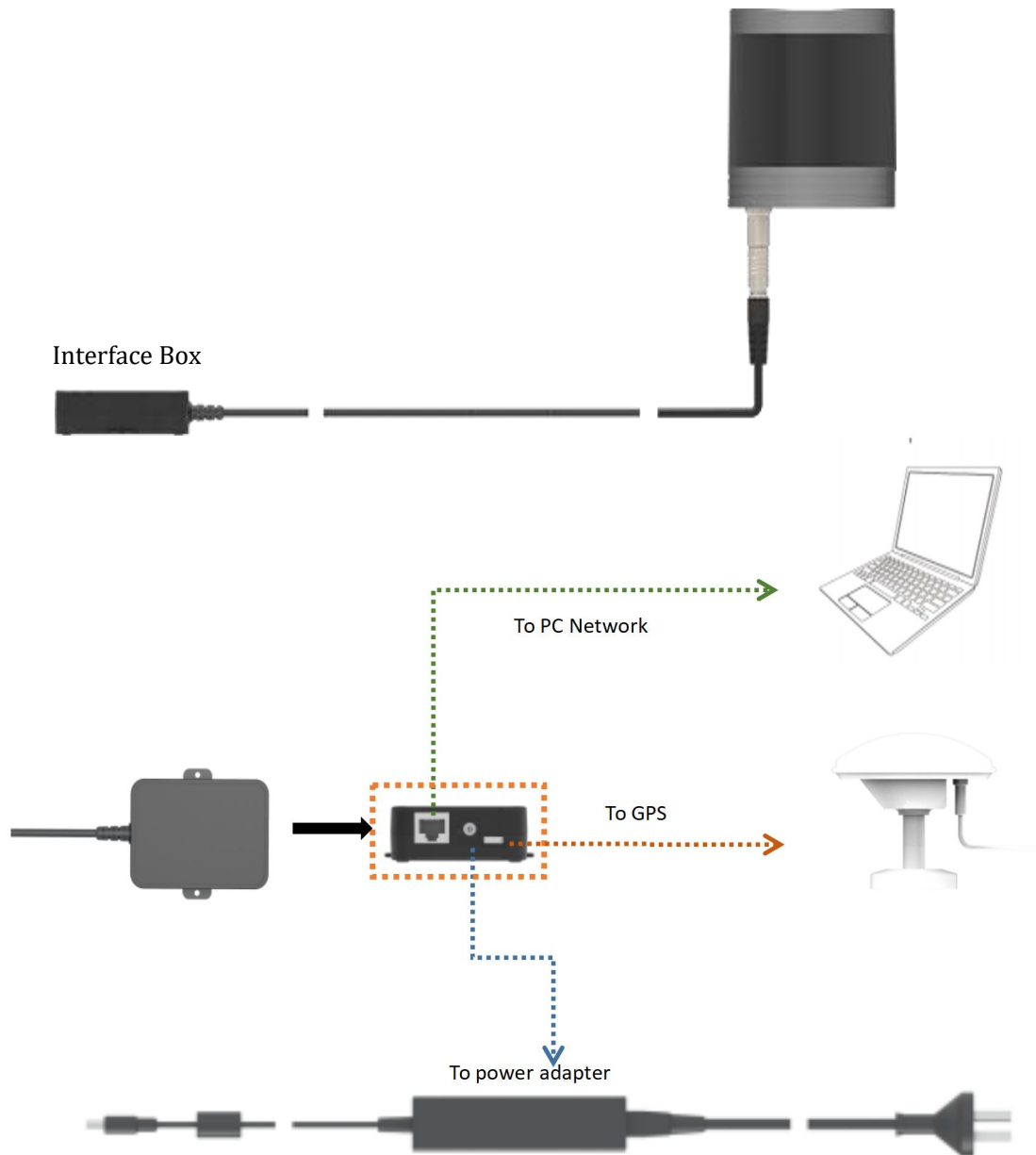

Figure 6 Interface Box Connection

5 Sensor Specifications and Features

5.1 Sensor Specification¹

5.1.1 Parameters

Sensor			
Laser Channels	32	FOV(Horizontal)	360°
Laser Wavelength	905nm	FOV(Vertical)	+ 10° to -16° (32° in total)
Laser Emission Angle (Full Angel)	Horizontal: 0.5mrad Vertical: 0.4mrad	Angular Resolution (Horizontal)	0.2°/ 0.4°
Laser Safety	Class 1 Eye-safe	Angular Resolution (Vertical)	Up to 0.5°
Measurement Range ²	0.2m to 150m (90m @10% Reflectivity NIST, refer to Table 3)	Ranging Accuracy (Typical) ³	±2cm
Blind Distance	0.2m	Frame Rate	10Hz/ 20 Hz
Rotation Speed		600/ 1200rpm(10/20Hz)	
Output			
Data Rate	576,000pts/s (Single Return Mode); 1,152,000pts/s(Dual Return Mode)		
Ethernet	100M-Base-T1		
Data Output Protocol	UDP packets over Ethernet		
UDP Packets Content	3D Coordinates, Calibrated Reflectivity Measurements, Time Stamps		
Mechanical			
Operating Voltage	9V - 32V	Dimension	φ97.5mm * H100 mm
Power Consumption ⁴	12W(Typical); 20W(Peak)	Operating Temperature ⁵	-30°C to +60°C

¹ The data above is only for serial production products, and may not be applicable to any samples, testing devices and other non-production versions. If you have any questions, please contact RoboSense Sales.

² The ranging accuracy takes a 50% NIST diffuse reflector as the target. The test results may be affected by environment conditions, including but not limited to factors such as ambient temperature and target distance.

³ The accuracy value is applicable to most channels, and there may exist differences between some channels.

⁴ The power consumption of the device may be affected by environment conditions, including but not limited to factors such as ambient temperature, target distance, target reflectivity, etc.

⁵ The operating temperature of the device may be affected by environment conditions, including but not limited to factors such as

Weight	0.99kg(LiDAR body)	Storage Temperature	-40°C to +85°C
Time Synchronization	\$GPRMC with 1PPS, PTP&gPTP	Sensor Protection	IP67

Table 5 Ranging Capability of LiDAR Channel

Channel No.	Vertical Angle (°)	10% NIST (m)	Range (m)
16	10°	50	150
32	7°	50	150
14	5°	90	150
30	3.5°	90	150
31	3°	90	150
7	2.5°	90	150
12	2°	90	150
23	1.5°	90	150
15	1°	90	150
28	0.5°	90	150
29	0°	90	150
5	-0.5°	90	150
10	-1°	90	150
21	-1.5°	90	150
13	-2°	90	150
26	-2.5°	90	150
27	-3°	90	150
3	-3.5°	90	150
8	-4°	90	150
19	-4.5°	90	150
11	-5°	90	150
24	-5.5°	90	150
25	-6°	90	150
1	-6.5°	90	150
6	-7°	50	150
9	-8°	50	150
22	-9°	50	150
4	-10°	50	150
17	-11°	50	150
20	-12°	50	150
2	-13.5°	50	150
18	-16°	50	150

ambient light and airflow changes.

5.2 Point Cloud Display

5.2.1 Coordinate Mapping

Since the data packet output by the LiDAR only provides the horizontal rotation angle and distance parameters, in order to present a 3D point cloud image, the angle and distance information in polar coordinates need to be converted into x, y, z coordinates in the Cartesian coordinate system, and the conversion formula is as follows:

$$\begin{cases} x = r \cos(\omega) \sin(\alpha); \\ y = r \cos(\omega) \cos(\alpha); \\ z = r \sin(\omega); \end{cases}$$

Where r is the measured distance, ω is the vertical angle of the laser, α is the horizontal rotation angle of the laser in the Polar Coordinate System, and x, y, z are the coordinate values in the Cartesian Coordinate System.

Note 1: ROS source code of RS-Helios-1610 has by default completed the coordinate conversion to conform to the right-handed coordinate system of ROS. The X-axis of ROS is the positive Y direction in Figure 1, and the Y-axis of ROS is the negative X direction in Figure 1.

Note 2: The origin of the LiDAR sensor coordinate is 63.5mm above the LiDAR base, on the center axis.

5.3 Reflectivity

RS-Helios-1610 measures the reflectivity of objects. The reflectivity is an index that measures the ability of an object to reflect light and is greatly related to the material of the object itself. Therefore, the reflectivity information can be used to distinguish objects of different materials.

RS-Helios-1610 reports calibrated reflectivity values from 0 to 255, among which diffuse reflectors report values from 0 to 100, and retroreflectors report values from 101 to 255. Black objects are with low reflectivity values, white objects are with high reflectivity values, the most ideal reflection reports the reflectivity value of 255.

Diffuse Reflectors

漫反射



Black, absorbent diffuse reflector
Reflectivity ≈ 0

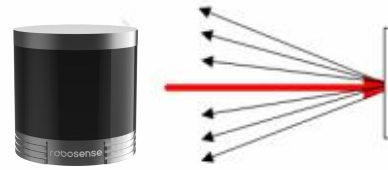

White, reflective diffuse reflector
Reflectivity < 100

Retro-Reflectors



Retro-reflector covered
with semi-transparent white surface
Reflectivity > 100



Retro-reflector without any
coverage
Reflectivity ≈ 255

Figure 7 Definition of Reflectivity

5.4 Laser Return Modes

5.4.1 Principle of Laser Return Modes

RS-Helios-1610 supports multiple laser return modes, namely: Strongest, Last, First and Dual. When set to Dual Return mode, the details of the target will increase, and the volume of data is twice that in the Single Return mode.

Due to beam divergence, multiple laser returns are possible from any single laser shot. After a laser pulse is shot, the beam size becomes larger and larger as it travels in the air, when a beam is large enough to hit multiple objects, it will produce multiple reflections.

RS-Helios-1610 analyzes the received multiple returns, and can be set to only report the strongest return, first return or the last return each time in the single return mode, or report the strongest and last return, the strongest and first return, or the first and the last return at the same time in dual return mode, depending on the laser return mode settings. If it is set to the strongest return mode, only the value of strongest return will be reported. Similarly, if it is set to the last return mode, only the value of the last return will be reported.

Note:

1. The sensor records both returns only when the distance between two objects is 1 meter or more.
2. When a laser pulse hits only one object, there is only the strongest return.
3. When a laser pulse hits two solid walls or other objects at two different distances, two returns will be produced. In this case, there are two situations:
 - (1) When the strongest return is not the last return, the strongest and last return will be reported;
 - (2) When the strongest return is the last return, the strongest return and the second strongest return will be reported.

5.4.2 Return Mode Flag

The RS-Helios-1610 is set in the Strongest Return mode at factory by default. If you need to change this settings, please refer to Appendix A.2 of this user manual for instructions. The 300th byte in a DIFOP packet is the flag of return mode, which corresponds to the following:

Table 6 Return Mode Flag

Flag	Return Mode
00	Dual Return
04	Strongest Return
05	Last Return
06	First return

5.5 Phase Locking

The phase locking feature, when a PPS pulse signal is triggered, asks the RS-Helios-1610 to rotate to a specific angle to fire laser pulses. When multiple RS-Helios-1610 sensors are used at the same time, the relative rotation angle between them is kept unchanged. The normal phase locking requires the normal and stable PPS pulse triggering signal.

Figure 8 shows the RS-Helios-1610 set with different phases. The red arrows indicate the firing angle of the sensor's laser at the moment it receives the rising edge of the PPS signal. In the cases below: 0 degrees, 135 degrees, and 270 degrees respectively.

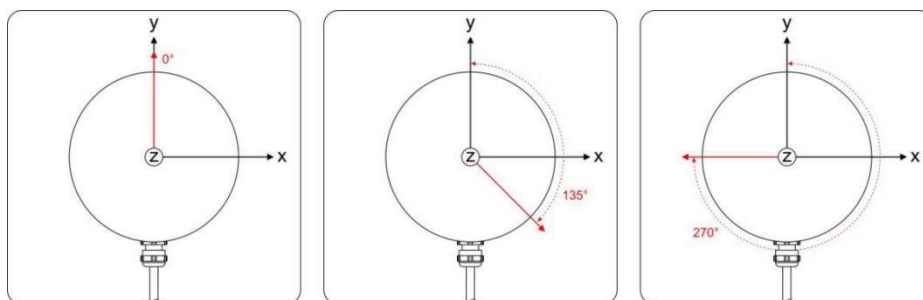

Figure 8 RS-Helios-1610 Different Phase Settings

Using the RS-Helios-1610 Web Interface, users can check and modify the Phase Locking settings, click **Setting > Phase Lock Setting**, for the "Phase Lock" parameter setting. The phase locking value can be set from 0 to 359.

5.6 Time Synchronization

RS-Helios-1610 supports GPS+PPS and PTP time synchronization methods. Users can use the RS-Helios-1610 Web Interface to set the time synchronization modes. (Please refer to Appendix A.2 for detailed instructions of setting by using Web Interface.)

RS-Helios-1610 can be connected to an external GPS module and can synchronize the sensor system time with the time provided by the GPS.

5.6.1 GPS Time Synchronization

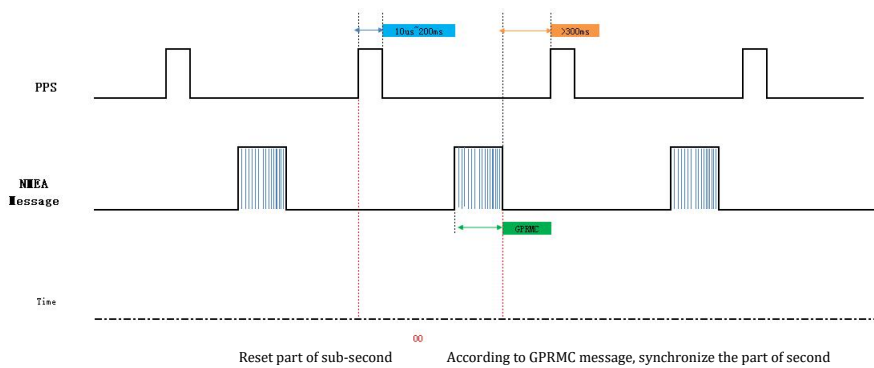

Figure 9 GPS Time Synchronization Timing Diagram

The GPS module continuously sends GPRMC message and PPS synchronization pulse signals to the sensor. The PPS synchronization pulse width is from 20ms to 200ms, and the GPRMC message must be sent within 500ms after the rising edge of the PPS synchronization pulse.

5.6.2 The Use of GPS for Time Synchronization

The GPS_REC interface in the Interface Box of the RS-Helios-1610 follows the RS232 level standard, as shown in the table below:

Table 7 GPS Receive Pin Definition

Level	Receive Pin Definition	
	GPS REC	GPS PULSE
RS232	Receive the RS232 serial data output by the GPS module	Receive the positive synchronization pulse signal output by the GPS module, the level is required to be 3.0V~15.0V

Note 1: The GPS_REC interface in the RS-Helios-1610 Interface Box is the SH1.0-6P female connector, and the pin

definition is as shown in Figure 2.

The external GPS module needs to set the serial output baud rate to 9600bps, 8 bits, no parity, 1 stop bit. RS-Helios-1610 only accepts the GPRMC sentence sent by the GPS module. The standard structure of the GPRMC sentence is as follows:

```
$GPRMC,<1>,<2>,<3>,<4>,<5>,<6>,<7>,<8>,<9>,<10>,<11>,<12>*hh
<1> UTC Time
<2> Receiver status, A=active, V=void
<3> Latitude
<4> Latitudinal hemisphere N (northern hemisphere) or S (southern hemisphere)
<5> Longitude
<6> Longitudinal hemisphere E (east longitude) or W (west longitude)
<7> Speed over the ground(knots)
<8> Track made good (degrees True)
<9> UTC date
<10> Magnetic declination
<11> Magnetic declination direction, E (east) or W (west)
<12> Mode indicator (A=autonomous, D=differential, E=estimated, N=not valid)
```

* The last hh is the XOR sum of all characters from \$ to *

Note:

1. The sending time interval of 1 PPS pulse needs to be controlled within $1s \pm 100\mu s$;
2. The status bit in the GPRMC message must be A valid before time synchronization is allowed;
3. The length of GPRMC messages sent by existing GPS modules on the market is not consistent. The length of GPRMC messages reserved in the DIFOP packet of RS-Helios-1610 is up to 86 bytes, which is compatible with the GPRMC message format sent by most GPS modules on the market. If an incompatibility occurs, please contact RoboSense technical support.

5.6.3 PTP Time Synchronization

PTP (Precision Time Protocol) is a time synchronization protocol, which itself is only used for high-precision time synchronization between devices, but it can also be borrowed for frequency synchronization between devices. Compared with various existing time synchronization mechanisms, PTP has the following advantages:

- 1) Compared with NTP (Network Time Protocol, Network Time Protocol), PTP can meet higher-precision time synchronization requirements. NTP can generally only achieve sub-second time synchronization accuracy, while PTP can reach sub-microsecond time synchronization accuracy.
- 2) Compared with GPS (Global Positioning System), PTP has lower construction and maintenance costs.

5.6.4 PTP wiring Method

To use the PTP synchronization method, you need to make the following preparations, and then connect according to the connection method shown in the figure below:

- 1) Select PTP mode in the web interface (please see Appendix A.2 Web Interface configuration);
- 2) Prepare a PTP Master timing host (plug and play, no additional configuration required);
- 3) Ethernet switch;
- 4) Device supporting PTP protocol

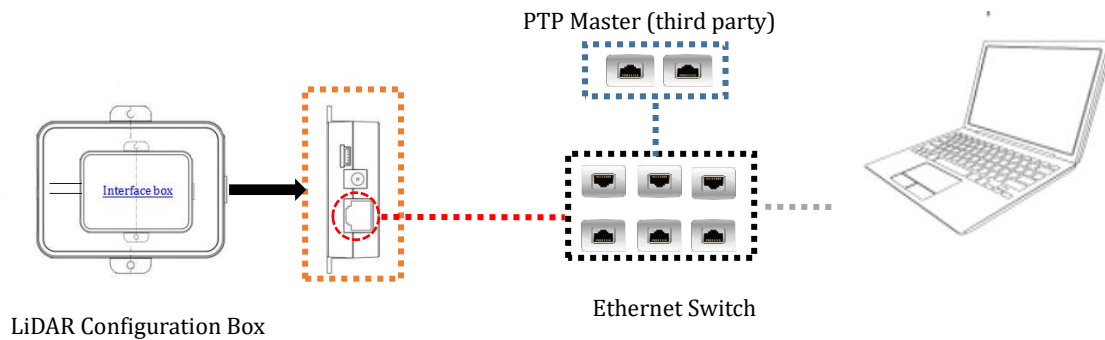

Figure 10 PTP Connecting Diagram

Note:

1. The PTP Master timing equipment is a third-party equipment that needs to be purchased by the user independently, which is not included in the RoboSense standard product shipping package.
2. As a PTP Slave device, our LiDAR only obtains the time sent by the PTP Master, and does not make accuracy judgments. If the time of the LiDAR deviates from the real time, please check whether the time provided by the PTP Master is accurate;
3. After the LiDAR is synchronized, the PTP Master is disconnected, and the time in the point cloud data packet will be superimposed according to the LiDAR's internal clock, and it will be reset after the LiDAR is powered off and restarted.

6 Communication Protocol

The communication between RS-Helios-1610 and computer is through Ethernet and by sending UDP packets. There are mainly two types of communication protocols, as shown in the following table:

Table 8 Communication Protocols

Protocol	Abbreviation	Function	Type	Packet Size
Main data Stream Output Protocol	MSOP	Output measured data	UDP	1248 bytes
Device Information Output Protocol	DIFOP	Output sensor information	UDP	1248 bytes

Note: The following sections describe and define the valid payload (1248byte) of the protocols.

- 1) The main data stream output protocol MSOP, encapsulates the distance, angle, reflectivity and other information measured by the LiDAR into an UDP packet and outputs to the computer;
- 2) Device information output protocol DIFOP, outputs various configuration information of the current state LiDAR to the computer;

6.1 MSOP and DIFOP

The UDP packet sent by RS-Helios-1610 has a payload of 1248 bytes, the data structure of the main data stream output protocol (MSOP) and device information output protocol (DIFOP) is as shown in the figure below:

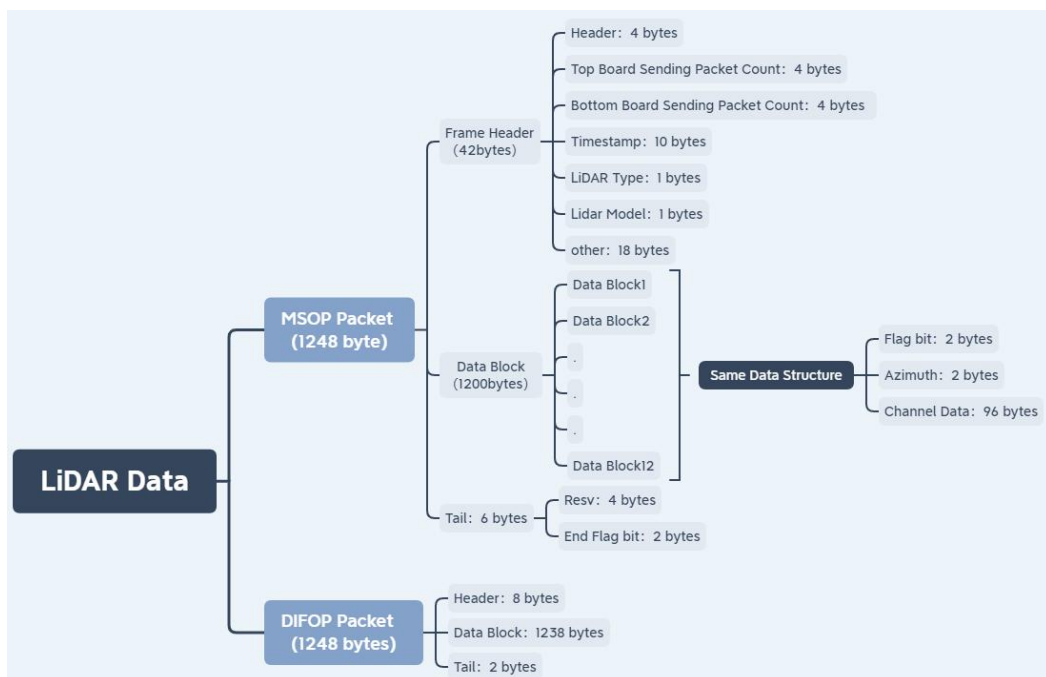

Figure 11 UDP Packet Structure

6.2 Main Data Stream Output Protocol (MSOP)

Main data Stream Output Protocol is abbreviated as MSOP

I/O type: device output, computer analysis

Default port number: 6699

6.2.1 Header

The header has 42 bytes and is used to identify the beginning of the UDP data packet. The structure of the Header is as shown in the table below:

Table 9 MSOP Header

Header (42 bytes)			
Field	Offset	Length (byte)	Description
Header ID	0	4	55_aa_05_5a
Protocol Version	4	2	00_01
Resv	6	2	
Top Board Sending Packet Count	8	4	4 Bytes in total, form a sequence with a increment of 3
Bottom Board Sending Packet Count	12	4	
Resv	16	1	
Range Resolution	17	1	1: 0.25cm; 0: 0.5cm
Angle pulse interval count	18	2	Unit: us
Timestamp	20	10	First 6 Bytes are second bits, last 4 bytes are microsecond bits
Resv	30	1	
LiDAR Type	31	1	Identify LiDAR model 0x06:RS-Helios
LiDAR Model	32	1	0x01:RS-Helios-5515 0x02:RS-Helios-1610 0x03:RS-Helios-16P 0x04:RS-Helios-1610
Resv	33	9	Reserved for future updates

Note: The time stamp is used to record the time of the sensor system, with a resolution of 1us. Please refer to the definition of time in Appendix B.13.

6.2.2 Data Blocks

As shown in the table below, the Data Blocks in the MSOP packet store the data measured by the sensor, and has a total of 1200 bytes. There are a total of 12 data blocks in one MSOP Packet. Each data block has 100 bytes and represents a complete measurement. Each data block starts with a 2-byte flag: 0xffee, followed by a 2-byte azimuth value (horizontal rotation angle), and 32 channel data (each channel data has 3 bytes) corresponding to a firing sequences of the 32 lasers (channel data 1... to channel data 32). Please refer to Section 6 of this manual for the relationship between channel number and vertical angle.

Table 10 Data Blocks Definitions

Data Block (1200 bytes)				
Data Block 1	Data Block 2	Data Block 3	Data Block n	Data Block 12
0xff,0xee	0xff,0xee	0xff,0xee	0xff,0xee	0xff,0xee
Azimuth 1	Azimuth 2	Azimuth 3	Azimuth n	Azimuth 12
Channel data 1	Channel data 1	Channel data 1	Channel data 1	Channel data 1
Channel data 2	Channel data 2	Channel data 2	Channel data 2	Channel data 2
...
Channel data 31	Channel data 31	Channel data 31	Channel data 31	Channel data 31
Channel data 32	Channel data 32	Channel data 32	Channel data 32	Channel data 32

Note: In the dual return mode, for each data block, the odd-numbered data block reports the strongest return data, and the even-numbered data block reports the last return data.

6.2.2.1 Channel Data

Each channel data has 3 bytes, the upper two bytes store distance information, and the lower one byte stores reflectivity information, as shown in the figure below.

Table 11 Channel Data

Channel data n (3 bytes)		
2 byte Distance		1 byte Reflectivity
Distance1 [15:8]	Distance2 [7:0]	Reflectivity

Distance information contains 2 bytes, the unit is cm, the resolution is 0.25cm.

No.	Time	Source	Destination
1	0.000000	192.168.1.200	192.168.1.102
2	0.000104	192.168.1.200	192.168.1.102
3	0.001150	192.168.1.200	192.168.1.102
4	0.001250	192.168.1.200	192.168.1.102
5	0.002308	192.168.1.200	192.168.1.102
6	0.003340	192.168.1.200	192.168.1.102
7	0.003443	192.168.1.200	192.168.1.102

Internet Protocol Version 4, Src: 192.168.1.200, Dst: 192.168.1.102

Version: 4
 Header Length: 20 bytes (5)

Differentiated Services Field: 0x00 (DSCP: CS0, ECN: Not-Set)
 Differentiated Services Codepoint: Default
 Explicit Congestion Notification: Not Set

Total Length: 1276

```

0000 54 e1 ad 10 54 63 00 0a 35 00 1e 22 08 00 45 00  T...
0010 04 fc 60 59 40 00 40 11 51 19 c0 a8 01 c8 c0 a8  ..Y
0020 01 66 1a 2b 1a 2b 04 e8 ba 14 55 aa 05 5a 00 01  -f+
0030 00 00 71 74 77 7a 00 03 b0 85 00 00 00 00 00 00  -qtv
0040 38 6e 0b ef 00 0d 4f fe 06 00 00 00 00 00 00 00  8n...
0050 84 1c 00 00 ff ee 88 db 01 40 5b 01 33 6c 01 3d  ...
0060 57 01 2f 7f 01 38 59 01 2d 7c 01 39 51 01 4b ff  W-/...
0070 01 38 51 01 4c ff 01 35 52 01 39 ff 01 35 50 01  -8Q:l
0080 48 ff 01 36 54 01 3f ff 01 3a 66 01 0f 3a 01 23  H...6I
0090 24 00 f3 2f 00 a7 21 00 88 31 00 91 24 00 78 3e  $-:/...
00a0 00 6e 28 00 63 48 00 5b 29 00 57 53 00 49 2c 00  -n(c
00b0 47 4f 00 44 3a 00 3f 4c ff ee 88 ef 01 40 5e 01  G0:D...
00c0 32 6c 01 3c 5a 01 2e 7d 01 37 5a 01 2d 7e 01 39  21-<
00d0 43 01 4b fe 01 37 45 01 4b ff 01 35 42 01 39 ff  C-K...
00e0 01 35 44 01 48 fe 01 35 49 01 3f ff 01 3a 53 01  -5D+
00f0 10 3e 01 22 24 00 f6 32 00 a7 22 00 88 32 00 91  ->:"$
0100 24 00 78 3b 00 6e 28 00 63 4b 00 5c 29 00 56 52  $-x;
0110 00 49 2c 00 47 51 00 44 3e 00 40 50 ff ee 89 06  -I,<
0120 01 40 5d 01 32 6b 01 3c 57 01 2e 90 01 37 5f 01  -@]4
0130 2d 7f 01 38 3b 01 4a ff 01 37 39 01 4b ff 01 35  -8;
0140 35 01 39 ff 01 35 35 01 47 ff 01 35 35 01 3f ff  5-9...
    
```

1. Calculate distance based on distance data in the data packet:

- 1) Find the distance value in the data packet and convert to a hexadecimal number: 0x01,0x40
- 2) Convert a 16bit unsigned integer: 0x0140
- 3) Convert to a decimal number: 320
- 4) Calculate according to the distances resolution
- 5) Result: 320*0.25 = 8m

2. Calculate azimuth based on azimuth data in the data packet:

- 1) Find the azimuth value in the data packet and convert to a hexadecimal number: 0x88, 0xdb
- 2) Convert to a 16bit unsigned integer: 0x88db
- 3) Convert to a decimal number: 35035

Divided by 100

- 4) Result:: 350.35 degrees

Figure 10 MSOP Packet

Note:

Red Box: Header ID;

Orange Box: Data Block flag;

Blue Box: Azimuth value of Channel data 1;

Green Box: Distance value of Channel data 1.

6.2.2.2 Azimuth Value

The azimuth value of each data block is the azimuth value reported by the first laser of the firing sequence of this data block. Azimuth value is recorded by angle encoder with the zero position of the angle encoder corresponding the zero degree of the azimuth value. The azimuth resolution is 0.01 degrees.

6.2.3 Tail

The Tail is 6 bytes in length, among which 4 bytes are reserved, and the other 2 bytes are 0x00 and 0xFF.

6.3 Device Info Output Protocol (DIFOP)

Device Info Output Protocol is abbreviated as DIFOP

I/O type: device output, computer read.

Default port number: 7788.

DIFOP is an "output-only" protocol to periodically send the LiDAR serial number (S/N), firmware version information, host computer driver compatibility information, network configuration information, calibration information, motor operating configuration, operating status, and fault diagnosis information to users. By reading DIFOP, users can learn specific information of various parameters of the LiDAR currently in use.

A complete DIFOP packet consists of a synchronization header, data area and a tail. Each DIFOP Packet is 1248-byte long, including an 8-byte long synchronization header, 1238-byte long data blocks and a 2-byte long tail.

The basic structure of the DIFOP packet is as shown in the table below.

Table 12 DIFOP Packet Structure

Segments	No.	Information Registers	Offset	Length (byte)
Header	0	DIFOP identification header	0	8
Data	1	Motor speed	8	2
	2	Ethernet	10	22
	3	FOV setting	32	4
	4	Reserved	36	2
	5	Motor phase lock	38	2
	6	Top board firmware version number	40	5
	7	Bottom board firmware version number	45	5
	8	Bottom board software version	50	5
	9	Motor firmware version number	55	5
	10	Sensor hardware version number	60	3
	11	Web page cgi version number	63	4
	12	Top board backup CRC	67	4
	13	Bottom board backup CRC	71	4
	14	Software app backup CRC	75	4

	15	Web page cgi backup CRC	79	4
	16	Ethernet gateway	83	4
	17	Subnet mask	87	4
	18	Reserved	91	201
	19	Serial number	292	6
	20	Zero angle offset	298	2
	21	Return mode	300	1
	22	Time Synchronization Mode	301	1
	23	Synchronization status	302	1
	24	Time	303	10
	25	Operating status	313	12
	26	Reserved	325	17
	27	Fault diagnosis	342	18
	28	Whether the code wheel is calibrated	360	1
	29	GPS PPS pulse trigger mode	361	1
	30	Reserved	362	20
	31	GPRMC	382	86
	32	Corrected vertical angle	468	96
	33	Corrected horizontal angle	564	96
	34	Reserved	660	586
Tail	35	Tail	1246	2

Note: The Header (the DIFOP identifier) in the table above is 0xA5,0xFF,0x00,0x5A,0x11,0x11,0x55,0x55, it can be used to identify the packet. The tail is 0x0F,0xF0.

For detailed definition of information registers as well as their usage, please refer to Appendix B of this user manual.

7 Vertical Angles and Precision Point Timing Calculation

7.1 Channel Number and Vertical Angle

RS-Helios-1610 has a vertical field of view from -16° to $+15^{\circ}$. The minimal angular resolution is 1° . The 32 laser heads are also called 32 channels. The laser channels and their designated vertical angles are as shown below.

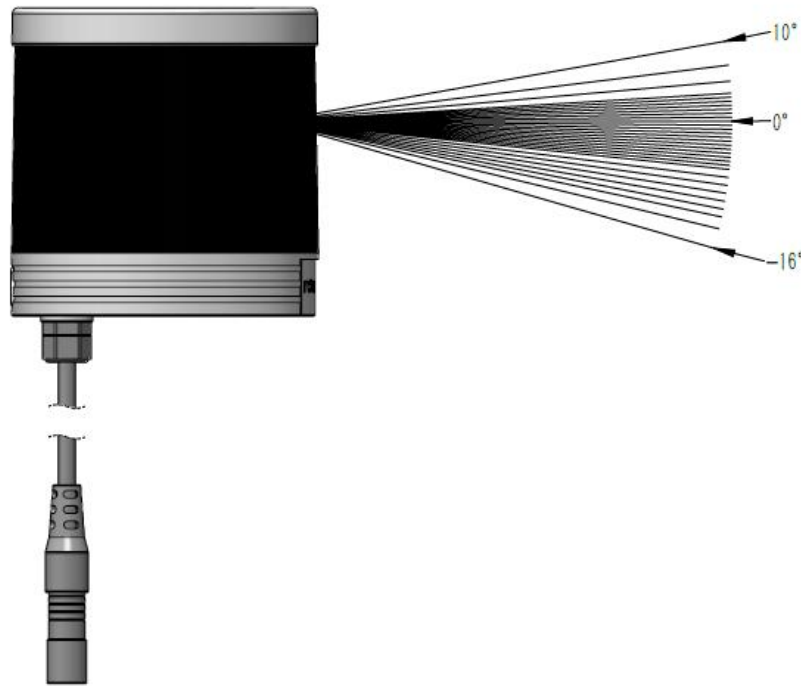

Figure 12 RS-Helios-1610 Vertical Angles

7.2 Exact Point Timing Calculation

The time required to complete one round of firing and recharging of 32 lasers is $55.56\mu\text{s}$. In each MSOP Packet, there are 12 data blocks, and each data block stores measurements of 1 firing sequences of 32 lasers, therefore, each MSOP Packet records 12 firing sequences of 32 lasers. It takes $55.56\mu\text{s}$ to complete one round of firing and recharging of the 32 lasers. RS-Helios-1610 has included the anti-interference feature, therefore the firing sequence of the 32 lasers is irregular. The exact point timing of different lasers in single return mode and dual return mode can be calculated according to the time offsets listed in the tables below:

Table 13 MSOP Packet Time Offset of Exact Laser Point Timing in Single Return Mode

Data Block											
1	2	3	4	5	6	7	8	9	10	11	12
0	55.56	111.11	166.67	222.22	277.78	333.33	388.89	444.44	500	555.56	611.11
1.57	57.13	112.69	168.24	223.8	279.35	334.91	390.46	446.02	501.57	557.13	612.69
3.15	58.7	114.26	169.82	225.37	280.93	336.48	392.04	447.59	503.15	558.7	614.26
4.72	60.28	115.84	171.39	226.95	282.5	338.06	393.61	449.17	504.72	560.28	615.84
6.3	61.85	117.41	172.97	228.52	284.08	339.63	395.19	450.74	506.3	561.85	617.41
7.87	63.43	118.98	174.54	230.1	285.65	341.21	396.76	452.32	507.87	563.43	618.98
9.45	65	120.56	176.11	231.67	287.23	342.78	398.34	453.89	509.45	565	620.56
11.36	66.91	122.47	178.02	233.58	289.13	344.69	400.24	455.8	511.36	566.91	622.47
13.26	68.82	124.38	179.93	235.49	291.04	346.6	402.15	457.71	513.26	568.82	624.38
15.17	70.73	126.28	181.84	237.39	292.95	348.51	404.06	459.62	515.17	570.73	626.28
17.08	72.64	128.19	183.75	239.3	294.86	350.41	405.97	461.52	517.08	572.64	628.19
18.99	74.54	130.1	185.65	241.21	296.77	352.32	407.88	463.43	518.99	574.54	630.1
20.56	76.12	131.67	187.23	242.78	298.34	353.9	409.45	465.01	520.56	576.12	631.67
22.14	77.69	133.25	188.8	244.36	299.92	355.47	411.03	466.58	522.14	577.69	633.25
23.71	79.27	134.82	190.38	245.93	301.49	357.05	412.6	468.16	523.71	579.27	634.82
25.29	80.84	136.4	191.95	247.51	303.06	358.62	414.18	469.73	525.29	580.84	636.4
26.53	82.08	137.64	193.19	248.75	304.31	359.86	415.42	470.97	526.53	582.08	637.64
29.01	84.57	140.12	195.68	251.23	306.79	362.34	417.9	473.46	529.01	584.57	640.12
27.77	83.32	138.88	194.44	249.99	305.55	361.1	416.66	472.21	527.77	583.32	638.88
30.25	85.81	141.36	196.92	252.47	308.03	363.59	419.14	474.7	530.25	585.81	641.36
31.49	87.05	142.6	198.16	253.72	309.27	364.83	420.38	475.94	531.49	587.05	642.6
32.73	89.53	145.09	200.64	256.2	311.75	367.31	422.86	478.42	533.98	589.53	645.09
33.98	88.29	143.85	199.4	254.96	310.51	366.07	421.62	477.18	532.73	588.29	643.85
35.22	90.77	146.33	201.88	257.44	313	368.55	424.11	479.66	535.22	590.77	646.33
36.46	92.01	147.57	203.13	258.68	314.24	369.79	425.35	480.9	536.46	592.01	647.57
37.7	93.26	148.81	204.37	259.92	315.48	371.03	426.59	482.14	537.7	593.26	648.81
38.94	94.5	150.05	205.61	261.16	316.72	372.27	427.83	483.39	538.94	594.5	650.05
40.18	95.74	151.29	206.85	262.4	317.96	373.52	429.07	484.63	540.18	595.74	651.29
41.42	96.98	152.54	208.09	263.65	319.2	374.76	430.31	485.87	541.42	596.98	652.54
42.67	98.22	153.78	209.33	264.89	320.44	376	431.55	487.11	542.67	598.22	653.78
43.91	99.46	155.02	210.57	266.13	321.68	377.24	432.8	488.35	543.91	599.46	655.02
45.15	100.7	156.26	211.81	267.37	322.93	378.48	434.04	489.59	545.15	600.7	656.26

Table 14 MSOP Packet Time Offset of Exact Laser Point Timing in Dual Return Mode

Data Block											
1	2	3	4	5	6	7	8	9	10	11	12
0	0	55.56	55.56	111.11	111.11	166.67	166.67	222.22	222.22	277.78	277.78
1.57	1.57	57.13	57.13	112.69	112.69	168.24	168.24	223.8	223.8	279.35	279.35
3.15	3.15	58.7	58.7	114.26	114.26	169.82	169.82	225.37	225.37	280.93	280.93
4.72	4.72	60.28	60.28	115.84	115.84	171.39	171.39	226.95	226.95	282.5	282.5
6.3	6.3	61.85	61.85	117.41	117.41	172.97	172.97	228.52	228.52	284.08	284.08
7.87	7.87	63.43	63.43	118.98	118.98	174.54	174.54	230.1	230.1	285.65	285.65
9.45	9.45	65	65	120.56	120.56	176.11	176.11	231.67	231.67	287.23	287.23
11.36	11.36	66.91	66.91	122.47	122.47	178.02	178.02	233.58	233.58	289.13	289.13
13.26	13.26	68.82	68.82	124.38	124.38	179.93	179.93	235.49	235.49	291.04	291.04
15.17	15.17	70.73	70.73	126.28	126.28	181.84	181.84	237.39	237.39	292.95	292.95
17.08	17.08	72.64	72.64	128.19	128.19	183.75	183.75	239.3	239.3	294.86	294.86
18.99	18.99	74.54	74.54	130.1	130.1	185.65	185.65	241.21	241.21	296.77	296.77
20.56	20.56	76.12	76.12	131.67	131.67	187.23	187.23	242.78	242.78	298.34	298.34
22.14	22.14	77.69	77.69	133.25	133.25	188.8	188.8	244.36	244.36	299.92	299.92
23.71	23.71	79.27	79.27	134.82	134.82	190.38	190.38	245.93	245.93	301.49	301.49
25.29	25.29	80.84	80.84	136.4	136.4	191.95	191.95	247.51	247.51	303.06	303.06
26.53	26.53	82.08	82.08	137.64	137.64	193.19	193.19	248.75	248.75	304.31	304.31
27.77	27.77	83.32	83.32	138.88	138.88	194.44	194.44	249.99	249.99	305.55	305.55
29.01	29.01	84.57	84.57	140.12	140.12	195.68	195.68	251.23	251.23	306.79	306.79
30.25	30.25	85.81	85.81	141.36	141.36	196.92	196.92	252.47	252.47	308.03	308.03
31.49	31.49	87.05	87.05	142.6	142.6	198.16	198.16	253.72	253.72	309.27	309.27
32.73	32.73	88.29	88.29	143.85	143.85	199.4	199.4	254.96	254.96	310.51	310.51
33.98	33.98	89.53	89.53	145.09	145.09	200.64	200.64	256.2	256.2	311.75	311.75
35.22	35.22	90.77	90.77	146.33	146.33	201.88	201.88	257.44	257.44	313	313
36.46	36.46	92.01	92.01	147.57	147.57	203.13	203.13	258.68	258.68	314.24	314.24
37.7	37.7	93.26	93.26	148.81	148.81	204.37	204.37	259.92	259.92	315.48	315.48
38.94	38.94	94.5	94.5	150.05	150.05	205.61	205.61	261.16	261.16	316.72	316.72
40.18	40.18	95.74	95.74	151.29	151.29	206.85	206.85	262.4	262.4	317.96	317.96
41.42	41.42	96.98	96.98	152.54	152.54	208.09	208.09	263.65	263.65	319.2	319.2
42.67	42.67	98.22	98.22	153.78	153.78	209.33	209.33	264.89	264.89	320.44	320.44
43.91	43.91	99.46	99.46	155.02	155.02	210.57	210.57	266.13	266.13	321.68	321.68
45.15	45.15	100.7	100.7	156.26	156.26	211.81	211.81	267.37	267.37	322.93	322.93

8 Troubleshooting

When using the sensor, users may encounter some common problems, this chapter lists some common problems and the corresponding solutions.

Problem	Solution
The red LED indicator in the Interface Box is off or blinking	<ul style="list-style-type: none"> ● Check whether the input power connection and polarity are normal.
LiDAR motor does not rotate	<ul style="list-style-type: none"> ● Check whether the LED indicators on the Interface Box are normal, and check whether the power input is normal. ● Check if the connection cable between the Interface Box and the LiDAR gets loose.
LiDAR keeps restarting at startup	<ul style="list-style-type: none"> ● Check whether the input power connection and polarity are normal. ● Check whether the voltage and current of the input power supply meet the requirements (voltage input\leq12V, input current\geq2A). ● Check whether the mounting base of the device is level or whether the fixing screws at the bottom of the LiDAR are too tight.
LiDAR rotates but no data output	<ul style="list-style-type: none"> ● Check whether the network connection is normal. ● Check whether the computer network configuration is correct. ● Use another software (such as wireshark) to check whether the packet output is normal. ● Turn off firewalls and other security software that may block the network. ● Check whether the power supply is normal ● Try to restart the sensor
Can see data in Wireshark but not in RSVIEW	<ul style="list-style-type: none"> ● Turn off the computer firewall, and allow the RSVIEW to bypass the firewall. ● Make sure that the IP of the computer is consistent with the IP of the LiDAR. ● Make sure that the Data Port setting on RSVIEW is correct. ● Make sure that the RSVIEW installation directory or configuration file storage directory only contain English characters. ● Make sure that the data packets received by wireshark are MSOP packets.
Frequent data dropouts	<ul style="list-style-type: none"> ● Check whether there is excessive traffic and/or collisions on network. ● Check whether there are other network devices in the network sending excessive broadcast packets, which slows the sensor down. ● Check whether the computer or the interfaces are fast enough to meet the packet flow requirements.

	<ul style="list-style-type: none"> ● Remove all other network devices and directly connect sensor to the computer to test whether there is packet loss.
GPS/PTP not synchronizing	<ul style="list-style-type: none"> ● Make sure that the synchronization mode has been switched to the correct mode on the web page ● Make sure that the GPS baud rate is 9600bps and serial port set to 8N1 (8 bits, no parity, 1 stop bit). ● Check whether the GPS signal level is 3.3V TTL or RS232 ● Make sure that the 1PPS pulse is continuous and the connection is correct ● Make sure that the GPRMC message of NMEA is correct ● Make sure that the GPS and Interface Box share the same ground ● Make sure that the GPS has received valid message ● Make sure that the GPS module is outdoors ● Check if the PTP Master synchronization protocol complies with the current PTP protocol ● Check if the PTP Master is working properly
No data output when sensor connected to a router	<ul style="list-style-type: none"> ● Turn off the DHCP function of the router or set the IP of the sensor to the correct IP inside the router
The point cloud, there is a fixed blank area that continuously rotates	<ul style="list-style-type: none"> ● This phenomenon is normal, because the ROS driver performs frame display according to a fixed number of packets, and the blank part of the data will be displayed in the next frame
RSVIEW software outputs point cloud into a ray	<ul style="list-style-type: none"> ● If you are using a windows 10 system, please set RSVIEW to run in the mode compatible with windows 7

Appendix A Web Interface

RS-Helios-1610 can only be accessed and controlled by its Web Interface, through which users can perform various operations on the RS-Helios-1610, including setting LiDAR parameters, viewing LiDAR operation status, updating firmware, etc. There are mainly four screens of the LiDAR Web Interface, namely the Device, Setting, Diagnostic, and System. The specific definitions on the functionality and feature of each screen is explained in the following pages.

The RS-Helios-1610 web address changes with the LiDAR IP. The factory default LiDAR IP is 192.168.1.200. If the user has changed the LiDAR IP, the web address will be changed to the newly set IP address.

After the LiDAR is connected and the correct configuration is completed according to the requirements, use the computer browser to access the LiDAR IP address (default Device IP "192.168.1.200") and enter the LiDAR web homepage, the homepage defaults to the "Device" page.

A.1 Device Screen

After accessing the LiDAR Web Interface, you will be at the "Device" screen directly, which shows information of the LiDAR currently in use:

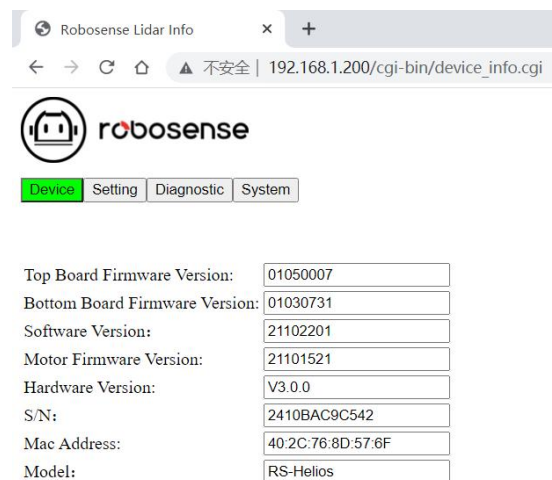

The screenshot shows a web browser window with the address bar displaying "192.168.1.200/cgi-bin/device_info.cgi". The page features the Robosense logo and a navigation menu with buttons for "Device", "Setting", "Diagnostic", and "System". Below the menu, a list of device information is displayed, each with a label and a corresponding text input field containing the value.

Top Board Firmware Version:	01050007
Bottom Board Firmware Version:	01030731
Software Version:	21102201
Motor Firmware Version:	21101521
Hardware Version:	V3.0.0
S/N:	2410BAC9C542
Mac Address:	40:2C:76:8D:57:6F
Model:	RS-Helios

- 1.Top Board: the top board firmware version
- 2.Bottom Board: the bottom board firmware version
- 3.Software Version: the software version
4. Motor Firmware Version: the firmware version of the motor;
5. Hardware Version: the hardware version;
- 6.S/N: serial number of LiDAR
- 7.Model: the product model number

Figure A-1 Front Page of Web Interface

A.2 Web Interface for Sensor Setting

Click the **Setting** button on the Web Interface, you will open the "Setting" screen, where you will find settings for Device IP, port number, return mode, rotation speed, etc. can be done at the General Setting page, and settings for angle phase at the Angle Phase Setting page. Definition of the functionality and features are as shown in the below:

Parameter Setting x +

不安全 | 192.168.1.200/cgi-bin/param_setting.cgi

robosense

Device **Setting** Diagnostic System

General Setting Angle Pulse Setting

Device IP Address: 192.168.1.200

Device IP Mask: 255.255.255.0

Device IP Gateway: 192.168.1.1

Destination IP Address: 192.168.1.102

MSOP Port Number(1025~65535): 6699

DIFOP Port Number(1025~65535): 7788

Return Mode: Strongest

FOV Setting(0~360): 0 to 360 DEG

Phase Lock Setting(0~360): 0 DEG

Rotation Speed(0/300/600/1200/1500): 600 RPM

Time Synchronization Source: PTP-GTP

Operation Mode: High Performance

Noise Filter: ON

Save

Figure a-2.1 General Setting Page of the LiDAR Web Interface

1. Communication of LiDAR supports both unicast (default) and broadcast modes. Destination IP address 255.255.255.255 indicates broadcast mode. The default factory setting of the LiDAR IP is 192.168.1.102
2. The MSOP and DIFOP port numbers can be configured in a range from 1025 to 65535;
3. The Return Mode has four options: Strongest(default), Last, First, and Dual;
4. The FOV can be set from 0° to 360°, when set, only the point cloud of the set FOV will be output.
5. The sensor rotation speed can be set, which only 600rpm(default), and 1200rpm are supported at the moment;
6. The Time Synchronization Source has options: GPS, PTP-P2P, PTP-E2E and PTP-gPTP;
7. Click the dropdown menu of "Operation Mode", users can select the working mode between Standby and High Performance (default). When Standby mode is selected, the LiDAR motor and transmitter will stop working.

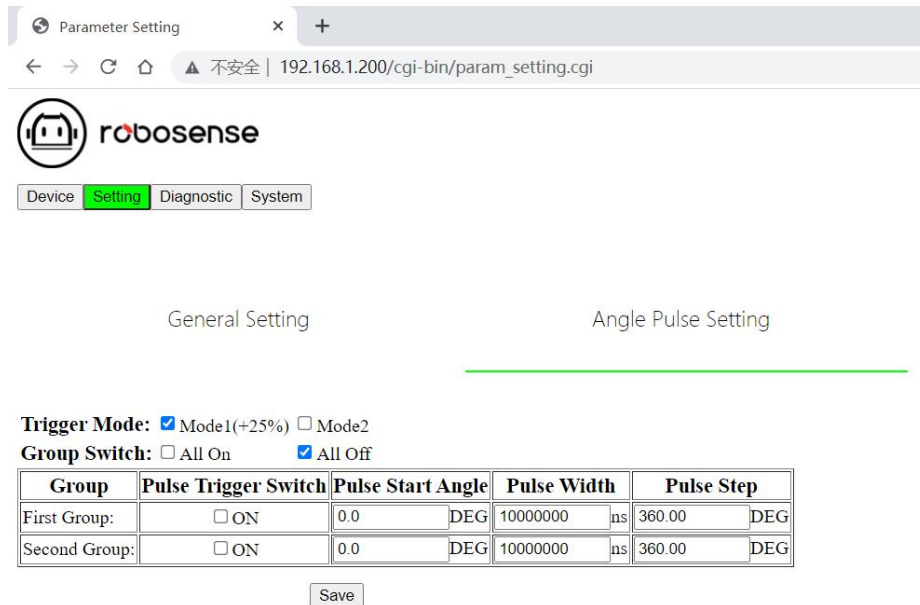

Figure A-2.2 Angle Pulse Setting Page of the LiDAR Web Interface

- 1. Angle Pulse Setting:** Set the angle pulse triggering feature, which by default is turned off.
- 2. Trigger Mode:** There are two starting angle trigger modes. Mode1 means that the starting pulse width is increased by 25% (default), and Mode2 means that the starting pulse width is not increased;
- 3. Group Switch:** Turn on/off the "Pulse Trigger Switch", when "All On" is checked, all groups of SYNC angle pulse trigger settings are activated for setting. The Group Switch is by default checked "All Off";
- 4. Group:** Referring to SYNC OUT group. The RS-Helios-1610 integrated sensor cable has reserved the SYNC_OUT1 pin and the SYNC_OUT2 pin, but the Interface Box has reserved only the SYNC_OUT1 pin. Please refer to *Table 2 GPS Port Definition* for more details. Therefore, only [First Group] is available, and the Second Group cannot be set;
- 5. Pulse Trigger Switch:** Turn on /off the "Pulse Trigger Switch" of a specific group of SYNC angle pulse trigger settings, when "ON" is checked, the settings are activated for editing, when not checked, the settings turn grey and are not editable.
- 6. Pulse Start Angle:** Setting the starting angle, the default value is 0, and the resolution is 0.1 degrees.
- 7. Pulse Width:** Setting the pulse width, the default value is 10ms, and the resolution is 20ns, the maximum duty cycle is 50%;
- 8. Pulse Step:** Setting the pulse step pitch, the default value is 360 degrees, and the resolution is 0.05°.

Note:

1. The Device IP and the Destination PC IP must share the same network segment, otherwise the connection

won't be successful;

2. The MSOP and DIFOP port number can be set from 1025 to 65535, and the MSOP port and DIFOP port cannot be set to the same port;
3. After every modification of the settings, you will need to click the "Save" button, if the system prompts "setting is successful", the new settings will take effect.

A.3 Diagnostic Screen

Click the **Diagnostic** button on the front page of the Web Interface, you will see the **Diagnostic Screen**, where you can learn the operating status of the sensor in real time, including the input voltage, current, sensor rotating speed, operating time, and temperature. The figure below shows the image of the Diagnostic screen and the features:

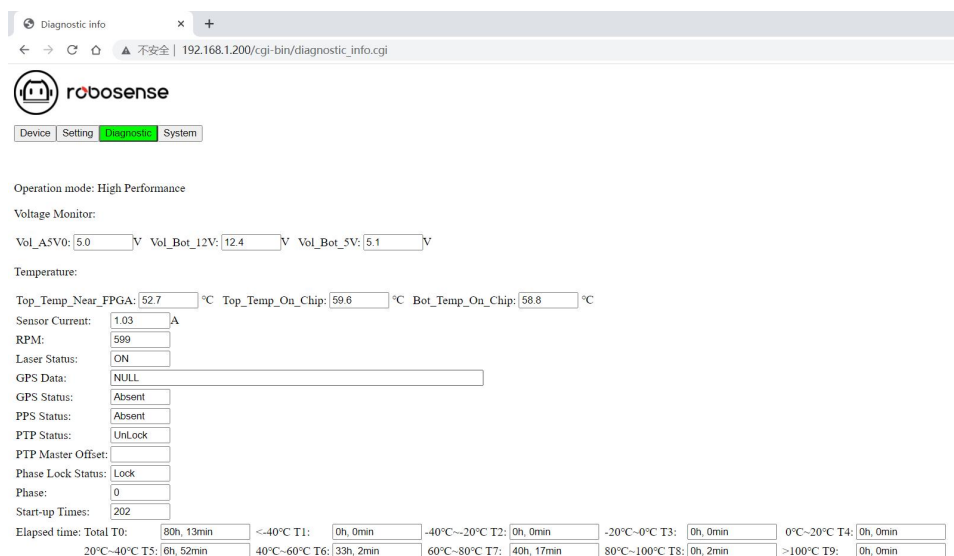

Figure A-3 Diagnostic Screen of the Web Interface

Description:

1. **Voltage Monitor:** shows the voltage of the sensor input power supply in real time. When the LiDAR Operation Mode is set in the Standby mode, the input box will turn red;
2. **Temperature:** users can view the current operating temperature of the LiDAR;
3. **RPM:** shows the LiDAR rotating speed in real time;
4. **Laser Status:** users can choose from "ON" (default) or "OFF", if the LiDAR Operation Mode is set in the Standby mode, the laser status is "OFF".
5. **Start-up Times:** users can learn the total number of start-up times of the LiDAR up to date, each power circle counts 1 star-up.
6. **Elapsed time Total TO:** users can view the total operating time of the LiDAR and the total operating time under different temperature range respectively.

Note:

1. The diagnostic screen is refreshed every second.
2. If the voltage/current box turns red, please check whether the LiDAR is currently in Standby mode, if not, check

whether the LiDAR is working normally;

3. The number of start-up times is refreshed after 1 minute after the LiDAR is circle powered again, and the operating time is refreshed every 1 minute.

A.4 System Screen

Click the **System** button on the front page of the Web Interface, you will see the **System Screen**, where you can update the top board firmware, bottom board firmware, software, web and motor firmware. The procedure of firmware update, taking the Top Board Firmware Update as an example, is as shown below:

1. Prepare the Top Board firmware that is going to be used for the update. Click the **Choose File** button to navigate to the folder where the new TOP Board firmware is located.

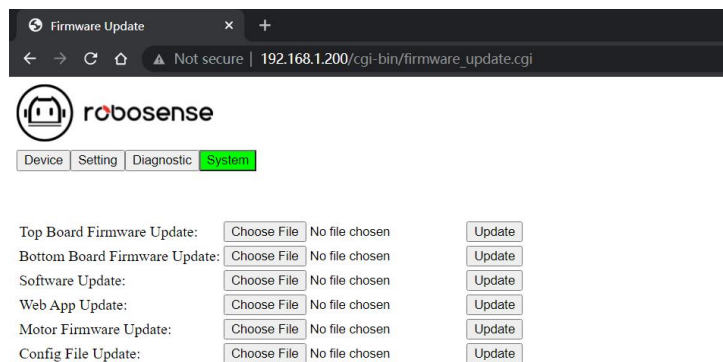

Figure A-4 Click Choose File to Find the New Firmware

2. Select the right firmware that is going to be used for the update, and click **Open** to upload the file. (The saving path of the firmware should only contain English characters)

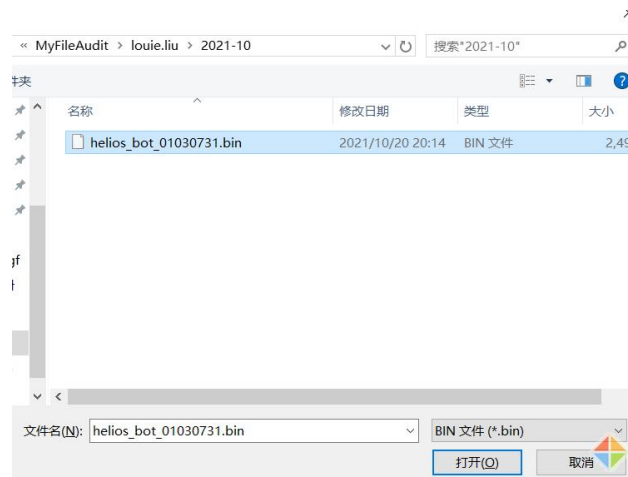
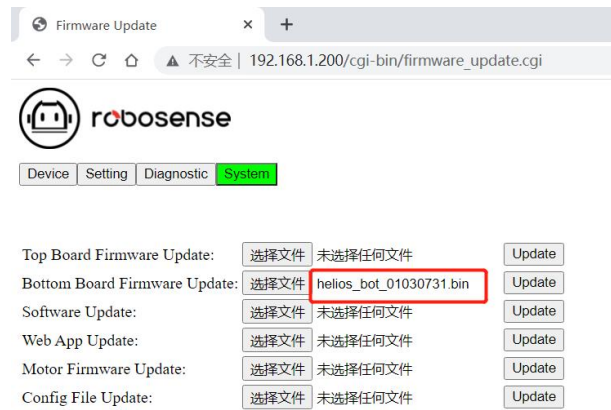

Figure A-5 Select the Right Firmware

3. When the new firmware is successfully uploaded, the file name of the firmware will appear in the box behind the bottom Board Firmware Update, click **Update** to initiate the update process.

Figure A-6 Click **Update**

3. After the Update process completes, the Web Interface will prompt Update Successful, and the LiDAR will automatically restart, after the sensor is restarted, load the Web Interface again to check if the firmware update is successful.

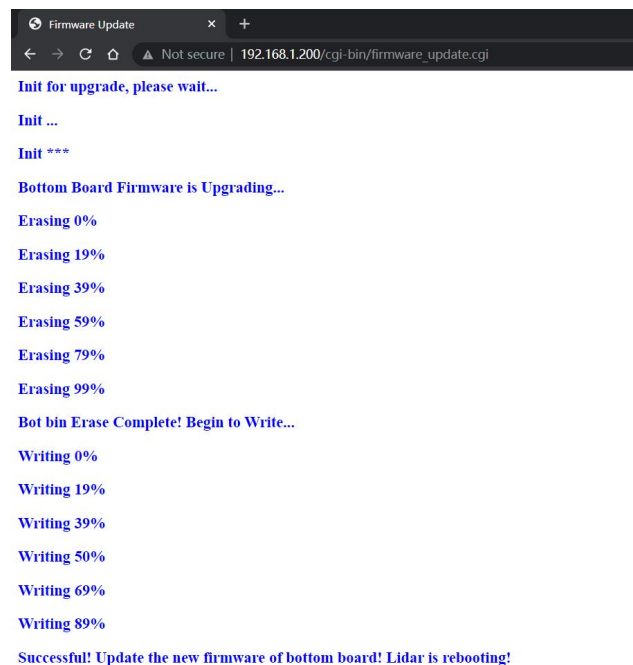

Figure A-7 Update Successful

Note: The upgrade package name must meet the following requirements before it can be upgraded normally, otherwise an error will be reported:

- Top board upgrade file: The necessary prefix "helios_top". The necessary suffix ".bin"
- Bottom board upgrade file: The necessary prefix "helios_bot_" The necessary suffix ".bin"
- Software upgrade file: The necessary prefix "helios_app_" The necessary suffix ".elf"
- Web App upgrade files: The necessary prefix "helios_cgi_" The necessary suffix ".tar.gz"
- Motor upgrade file: The necessary prefix "helios_mot_" The necessary suffix ".hex"

Appendix B Information Registers

Here are definitions and more details on the information registers as mentioned in Section 5.

B.1 Motor Speed (MOT_SPD)

MOT_SPD (2 bytes in total)						
Byte No.	byte1	byte2				
Function	MOT_SPD					

Register description:

- (1) This register is used to configure the motor rotation direction and motor speed;
- (2) The data storage adopts the big-endian format.
- (3) Supported rotation speed:
 (byte1==0x04) && (byte2==0xB0): speed 1200rpm, clockwise rotation;
 (byte1==0x02) && (byte2==0x58): speed 600rpm, clockwise rotation;
 If set with data other than the above described, the rotation speed of the motor is 0.

B.2 Ethernet (ETH)

ETH (22 bytes in total)									
Byte No.	byte1	byte2	byte3	byte4	byte5	byte6	byte7	byte8	
Function	LIDAR_IP				DEST_PC_IP				
Byte No.	byte9	byte10	byte11	byte12	byte13	byte14	byte15	byte16	
Function	MAC_ADDR						port1		
Byte No.	byte17	byte18	byte19	byte20	byte21	byte22			
Function	port2		port3		Port4				

Register description:

- (1) LIDAR_IP is the source IP address of the LiDAR. It takes 4 bytes
- (2) DEST_PC_IP is the IP address of the destination PC. It takes 4 bytes
- (3) MAC_ADDR is the LiDAR MAC address.
- (4) port1 to port4 are port number information.

port1 is the port for LiDAR to output MSOP packets and port2 is the port for destination PC to receive MSOP packets. port3 is the port for LiDAR to output DIFOP packets and port4 is the port for destination PC to receive DIFOP packets. By default, we suggest port1 and port2 to be set the same, port3 and port4 to be set the same.

B.3 FOV Setting (FOV_SET)

FOV_SET (4 bytes in total)						
Byte No.	byte1	byte2	byte3	byte4		
Function	FOV_START		FOV_END			

Register Description:

Set the azimuth range that the sensor can output valid data, the values of FOV_START and FOV_END could be any integer between 0 to 36000, corresponding 0~360°, the data storage adopts the big endian ordering. For example: byte1 = 0x5d, byte2 = 0xc0, byte3 = 0x1f, byte4 = 0x40, so:

$$\text{FOV_START} = 93 * 256 + 192 = 24000$$

$$\text{FOV_END} = 31 * 256 + 64 = 8000$$

Which indicates that the azimuth range for valid data output is from 240.00° to 80.00° in clockwise direction.

Note: In all above calculations, bytes have been converted from hexadecimal to decimal.

B.4 Motor Phase Offset (MOT_PHASE)

MOT_PHASE(2 bytes in total)						
Byte No.	byte1	byte2				
Function	MOT_PHASE					

Register description:

This register can be used together with the PPS pulse of GPS to adjust the phase offset of the motor at the top of seconds. The value can be set from 0 to 360 corresponding 0 to 360°. The data storage adopts the big endian ordering. For example: the byte1=0x01、byte2=0x0e, so the motor phase should be $1 * 256 + 14 = 270$.

Note: In all above calculations, bytes have been converted from hexadecimal to decimal.

B.5 Top Board Firmware Version (TOP_FRM)

TOP_FRM(5 bytes in total)						
Byte No.	byte1	byte2	byte3	byte4	byte5	
Function	TOP_FRM					

Register description:

This register corresponds to the top board firmware version:

Register value: 00 01 06 05 00

Segmentation of value: 0x0001060500

Top board firmware version: 01060500

B.6 Bottom Board Firmware Version(BOT_FRM)

BOT_FRM(5bytes in total)						
Byte No.	byte1	byte2	byte3	byte4	byte5	
Function	BOT_FRM					

Register description:

This register corresponds to the top board firmware version:

Register value: 00 01 03 01 00

Segmentation of value: 0x0001030100

Bottom board firmware version: 01030100

B.7 Motor Firmware Version(MOT_FRM)

MOT_FRM (5 bytes in total)					
Byte No.	byte1	byte2	byte3	byte4	byte5
Function	MOT_FRM				

Register description:

This register corresponds to the motor firmware version:

Register value: 00 21 11 23 21

Segmentation of value: 0x0021112321

Motor firmware version: 21112321

B.8 Software Version(SOF_FRM)

SOF_FRM (5 bytes in total)					
Byte No.	byte1	byte2	byte3	byte4	byte5
Function	SOF_FRM				

Register description:

This register corresponds to the Software Firmware version:

Register value: 00 22 04 18 01

Segmentation of value: 0x0022041801

Motor firmware version: 22041801

B.9 Corrected Vertical Angle(COR_VERT_ANG)

COR_VERT_ANG(96bytes in total)									
Byte No.	byte1	byte2	byte3	byte4	byte5	byte6	byte7	byte8	byte9
Function	Channel 1 vertical angle			Channel 2 vertical angle			Channel 3 vertical angle		
Byte No.	byte10	byte11	byte12	byte13	byte14	byte15	byte16	byte17	byte18
Function	Channel 4 vertical angle			Channel 5 vertical angle			Channel 6 vertical angle		
Byte No.	byte19	byte20	byte21	byte22	byte23	byte24	byte25	byte26	byte27
Function	Channel 7 vertical angle			Channel 8 vertical angle			Channel 9 vertical angle		
Byte No.	byte28	byte29	byte30	byte31	byte32	byte33	byte34	byte35	byte36
Function	Channel 10 vertical angle			Channel 11 vertical angle			Channel 12 vertical angle		
Byte No.	byte37	byte38	byte39	byte40	byte41	byte42	byte43	byte44	byte45
Function	Channel 13 vertical angle			Channel 14 vertical angle			Channel 15 vertical angle		
Byte No.	byte46	byte47	byte48	byte49	byte50	byte51	byte52	byte53	byte54
Function	Channel 16 vertical angle			Channel 17 vertical angle			Channel 18 vertical angle		
Byte No.	byte55	byte56	byte57	byte58	byte59	byte60	byte61	byte62	byte63
Function	Channel 19 vertical angle			Channel 20 vertical angle			Channel 21 vertical angle		
Byte No.	byte64	byte65	byte66	byte67	byte68	byte69	byte70	byte71	byte72
Function	Channel 22 vertical angle			Channel 23 vertical angle			Channel 24 vertical angle		
Byte No.	byte73	byte74	byte75	byte76	byte77	byte78	byte79	byte80	byte81
Function	Channel 25 vertical angle			Channel 26 vertical angle			Channel 27 vertical angle		
Byte No.	byte82	byte83	byte84	byte85	byte86	byte87	byte88	byte89	byte90
Function	Channel 28 vertical angle			Channel 29 vertical angle			Channel 30 vertical angle		
Byte No.	byte91	byte92	byte93	byte94	byte95	byte96			
Function	Channel 31 vertical angle			Channel 32 vertical angle					

Register description:

(1) The channel vertical angle value is composed of 3 bytes, among which the 1st byte is used to indicate positive/negative angle, the 2nd and 3rd bytes indicate angle value. The data storage adopts big-endian format;

(2) The 1st byte of the vertical angle value, 0x00 means a positive angle, 0x01 means a negative

angle;

(3) The angle resolution: LBS=0.01;

(4) For example, the register value of channel 1: byte1=0x00, byte2=0x05(converted to decimal is 5), byte3=0xd6(converted to decimal is 214), then the vertical angle of channel 1 is: $(5*256+ 214) * 0.01=14.95^{\circ}$.

B.10 Corrected Horizontal Angle(COR_HOR_ANG)

COR_HOR_ANG(96 bytes in total)									
Byte No.	byte1	byte2	byte3	byte4	byte5	byte6	byte7	byte8	byte9
Function	Channel 1 horizontal angle			Channel 2 horizontal angle			Channel 3 horizontal angle		
Byte No.	byte10	byte11	byte12	byte13	byte14	byte15	byte16	byte17	byte18
Function	Channel 4 horizontal angle			Channel 5 horizontal angle			Channel 6 horizontal angle		
Byte No.	byte19	byte20	byte21	byte22	byte23	byte24	byte25	byte26	byte27
Function	Channel 7 horizontal angle			Channel 8 horizontal angle			Channel 9 horizontal angle		
Byte No.	byte28	byte29	byte30	byte31	byte32	byte33	byte34	byte35	byte36
Function	Channel 10 horizontal angle			Channel 11 horizontal angle			Channel 12 horizontal angle		
Byte No.	byte37	byte38	byte39	byte40	byte41	byte42	byte43	byte44	byte45
Function	Channel 13 horizontal angle			Channel 14 horizontal angle			Channel 15 horizontal angle		
Byte No.	byte46	byte47	byte48	byte49	byte50	byte51	byte52	byte53	byte54
Function	Channel 16 horizontal angle			Channel 17 horizontal angle			Channel 18 horizontal angle		
Byte No.	byte55	byte56	byte57	byte58	byte59	byte60	byte61	byte62	byte63
Function	Channel 19 horizontal angle			Channel 20 horizontal angle			Channel 21 horizontal angle		
Byte No.	byte64	byte65	byte66	byte67	byte68	byte69	byte70	byte71	byte72
Function	Channel 22 horizontal angle			Channel 23 horizontal angle			Channel 24 horizontal angle		
Byte No.	byte73	byte74	byte75	byte76	byte77	byte78	byte79	byte80	byte81
Function	Channel 25 horizontal angle			Channel 26 horizontal angle			Channel 27 horizontal angle		
Byte No.	byte82	byte83	byte84	byte85	byte86	byte87	byte88	byte89	byte90
Function	Channel 28 horizontal angle			Channel 29 horizontal angle			Channel 30 horizontal angle		
Byte No.	byte91	byte92	byte93	byte94	byte95	byte96			
Function	Channel 31 horizontal angle			Channel 32 horizontal angle					

Register description:

(1) The channel horizontal angle value is composed of 3 bytes, among which the 1st byte is used to indicate positive/negative angle, the 2nd and 3rd bytes indicate angle value. The data storage adopts big-endian format;

(2) The 1st byte of the horizontal angle value, 0x00 means a positive angle, 0x01 means a negative angle;

(3) The angle resolution: LBS=0.01;

(4) For example, the register value of channel 1: byte1=0x01, byte2=0x01 (converted to decimal is 1), byte3=0x96 (converted to decimal is 150), then the vertical angle of channel 1 is:

$$-(1*256+150) * 0.01 = -4.06^\circ$$

B.11 Serial Number(SN)

SN(6 bytes in total)						
Byte No.	1byte	2byte	3byte	4byte	5byte	6byte
Function	SN					

Similar to the MAC address, it indicates the serial number of the LiDAR with a total of 6 bytes in hexadecimal.

B.12 Software Version (SOFTWARE_VER)

SOFTWARE_VER(2 bytes in total)						
Byte No.	byte1	byte2				
Function	SOFTWARE_VER					

This register describes the version compatibility of the host computer.

B.13 UTC Time (UTC_TIME)

UTC_TIME (10 bytes in total)									
Byte No.	byte1	byte2	byte3	byte4	byte5	byte6	byte7	byte8	
Function	sec						ns		
Byte No.	byte9	byte10							
Function	ns								

Note: the range of ns is from 0 to 999999999.

B.14 STATUS (STATUS)

STATUS (18 bytes in total)								
Byte No.	byte1	byte2	byte3	byte4	byte5	byte6	byte7	byte8
Function	ldat1_reg		Vdat		Vdat_12V_reg		Vdat_5V_reg	
Byte No.	byte9	byte10	byte11	byte12	byte13	byte14	byte15	byte16
Function	Vdat_2V5_reg		Vdat_APD		Internal debug			
Byte No.	17byte	18byte	19byte	20byte	21byte	22byte	23byte	24byte
Function	Internal debug							
Byte No.	25byte	26byte	27byte	28byte	29byte			
Function	Internal debug							

Note: 【Value】 is the decimal value calculated after the byte at the corresponding position, in big-endian mode, with the high order first and the low order last.

Register description:

(1) ldat is the current of the LiDAR power supply. The current value is composed of 2 bytes.

Current calculation formula:

$$\text{ldat} = \text{Value_temp} / 4096 * 5A$$

For example, when byte1 = 0xc8, byte2 = 0x02, the actual current value:

$$\text{ldat} = \text{Value_temp} / 4096 * 5A = 0x02c8 / 4096 * 5A = 0.87A$$

(2) Vdat has 5 different voltage values, each voltage value has 2 bytes, calculation formula of the 5 voltages are as below:

$$\text{Vdat} = \text{value} / 4096 \text{ V}$$

$$\text{Vdat_12V_reg} = \text{value} / 4096 * 24.5V$$

$$\text{Vdat_5V_reg} = \text{value} / 4096 * 11 \text{ V}$$

$$\text{Vdat_2V5_reg} = \text{value} / 4096 * 10 \text{ V}$$

$$\text{Vdat_APD} = 516.65 * (\text{value}) / 4096 - 465.8 \text{ V (negative value)}$$

The unit above is volt (V).

B.15 Fault Diagnosis (FALT_DIGS)

FALT_DIGS (40 bytes in total)								
Byte No.	byte1	byte2	byte3	byte4	byte5	byte6	byte7	byte8
Function	temperature1		temperature2		temperature3		temperature4	

Byte No.	byte9	byte10	byte11	byte12	byte13	byte14	byte15	byte16
Function	temperature 5		r_rpm		lane_up	lane_up_cnt		Top_Status
Byte No.	byte17	byte18	byte19	byte20	byte21	byte22	byte23	byte24
Function	Top_Status	GPS_Status	Internal debug					
Byte No.	byte25	byte26	byte27	byte28	byte29	byte30	byte31	byte32
Function	Internal debug							
Byte No.	byte33	byte34	byte35	byte36	byte37	byte38	byte39	byte40
Function	Internal debug							

Note: 【Value】 is the decimal value calculated after the byte at the corresponding position, in big-endian mode, with the high order first and the low order last.

Register description:

(1) temperature2, temperature3, temperature4 are temperatures of other boards. Temperature calculation formula:

$$\text{Temperature2\&3\&4} = 200 * (\text{value}) / 4096 - 50$$

temperature1, temperature5 are the temperature of the top board/bottom board FPGA chip respectively. The temperature value is composed of 2 bytes, and the calculation formula is:

$$\text{Temperature1\&5} = 503.975 * (\text{value}) / 4096 - 273.15$$

(2) byte18 is the GPS signal input status register gps_st. This register uses 3 bits to indicate whether the currently connected PPS signal and GPRMC signal are valid, and to indicate whether the current system time is the local count time of the sensor or the synchronized UTC time. The bit definitions are as follows:

GPS_ST			
Byte No.	Function	Status	Description
bit0	PPS flag: PPS_LOCK	0	PPS signal is invalid
		1	PPS signal is valid
bit1	GPRMC flag: GPRMC_LOCK	0	GPRMC signal is invalid
		1	GPRMC signal is valid
bit2	UTC Lock flag: UTC_LOCK	0	LIDAR internal time is not synchronized with UTC time
		1	LIDAR internal time is synchronizing with UTC time
Bit3	GPRMC Input	0	No input

	Status	1	with input
Bit4	PPS Input Status	0	No input
		1	with input
bit5~bit7	Reserved	x	N/A

(3) The real-time speed of the motor is composed of byte32 and byte33. The calculation formula is as follows: Motor real-time speed = value

For example, when byte32 = 0x58, byte33 = 0x02, $r_rpm=0x0258=600rpm$.

(4) Other registers are used for internal debugging

B.16 GPRMC Data Packet-ASCII Code Data Type

86 bytes are reserved for the GPRMC data packet. According to the length of the GPRMC message output by the external GPS module, the received GPRMC message is self-adaptively stored and can be analyzed and viewed in ASCII code.

Appendix C RSView

This appendix gets you started with RSView. It shows you how to use the application to acquire, visualize, save, and replay your RS-Helios-1610 data. You can also use other free tools, such as Wireshark or tcp-dump. But RSView is free and relatively easy to use. The version used here is RSView3.1.7.

C.1 Software Features

RSView provides real-time visualization of any RoboSense LiDAR data. RSView can also review pre-recorded data stored in “pcap” (Packet Capture) files, but RSView still does not support playing pcapng files. RSView displays distance measurements from a RoboSense LiDAR as point data. It supports custom-colored display of variables such as intensity-of-return, time, distance, azimuth, and laser ID. The data can be exported in CSV format. The RSView 3.1.3 or later version supports generating LAS format point cloud files, while the previous versions of RSView do not support generating point cloud files in LAS, XYZ, or PLY formats.

Functionality and features of RSView include:

- Visualize live streaming sensor data over Ethernet
- Record live sensor data to pcap files
- Visualize sensor data from a recorded pcap file
- Different types of visualization modes, such as distance, time, azimuth, etc.
- Display point data in a spreadsheet
- Export point cloud data in CSV format
- Distance measurement tool
- Display multiple frames of data simultaneously (Trailing Frames)
- Display or hide subsets of lasers
- Crop views

C.2 Install RSView

Installer for RSView is provided for Windows 64-bit system and there is no need for other dependencies. You can download the latest installer from RoboSense website (<http://www.robosense.ai/resource>). Launch the downloaded installer and follow the instructions to finish the installation. After installation is completed, a shortcut will be generated on the desktop. Make sure the installation path only contains English characters.

C.3 Set Up Network

As mentioned in Section 2, the LiDAR has a factory default IP address to be sent to computer. Therefore, by default, the static IP address of the computer needs to be set to 192.168.1.102, and the subnet mask needs to be set to 255.255.255.0. In addition, you need to make sure that the RSView is not blocked by firewalls or third-party security software.

C.4 Visualize Streaming Sensor Data

1. Connect LiDAR to power and connect to computer by network cable.
2. Right Click to start the RSView application with **Run As Administrator**.
3. Click on **File > Open** and select **Sensor Stream** (Figure C-1).

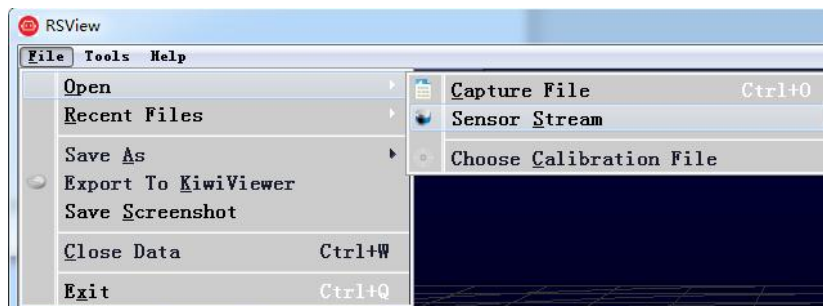

Figure C-1 RSView Open Sensor Stream

4. The Sensor Configuration dialog will appear. In "Type of Lidar", Chose RSHelios. In "Intensity", chose Mode3. Then click **OK**, as shown in Figure C-2:

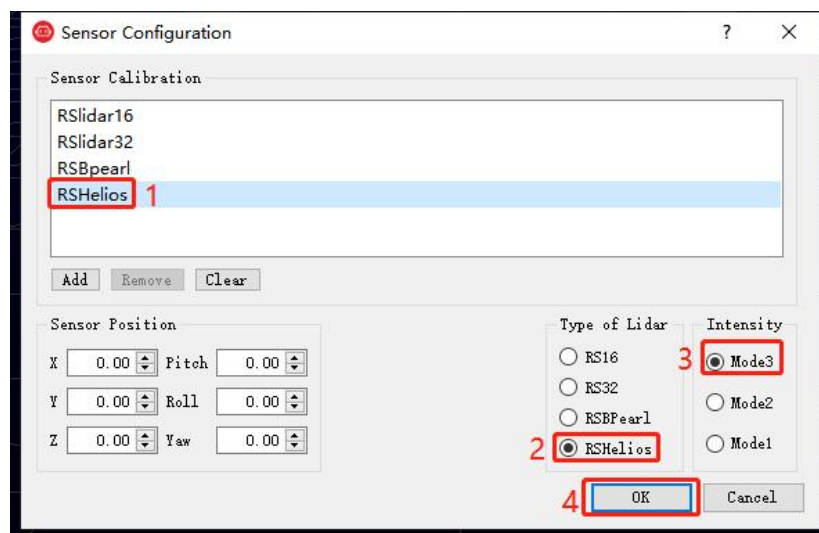

Figure C-2 Select RSHelios Parameter Configuration File

5. RSView begins displaying the sensor data stream (Figure C-3). The stream can be paused by pressing the **Play** button, pressing again, the stream resumes.

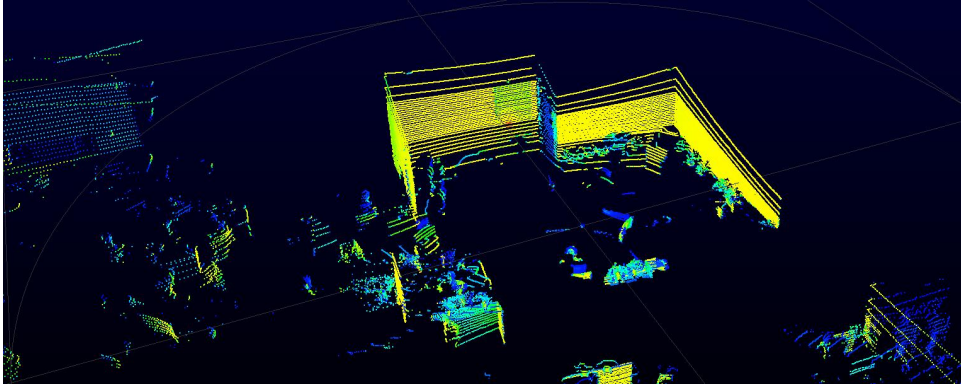

Figure C-3 Sensor Stream Data Display in RSView

C.5 Capture Streaming Sensor Data to PCAP File

1. Click the **Record** button when streaming (Figure C-4).



Figure C-4 R RSView Record Button.

2. In the “Choose Output File” dialog that pops up, set the save path and file name, and then click the **Save (S)** button (Figure C-5). RSView will start to write the packet file into the target pcap file. (Note: RS-Helios LiDAR will generate huge volume of data. As the recording time gets longer, the target pcap file will become larger. Therefore, it is better to save the recorded file to the HDD or SSD instead of a slow subsystem such as a USB drive or network drive.)

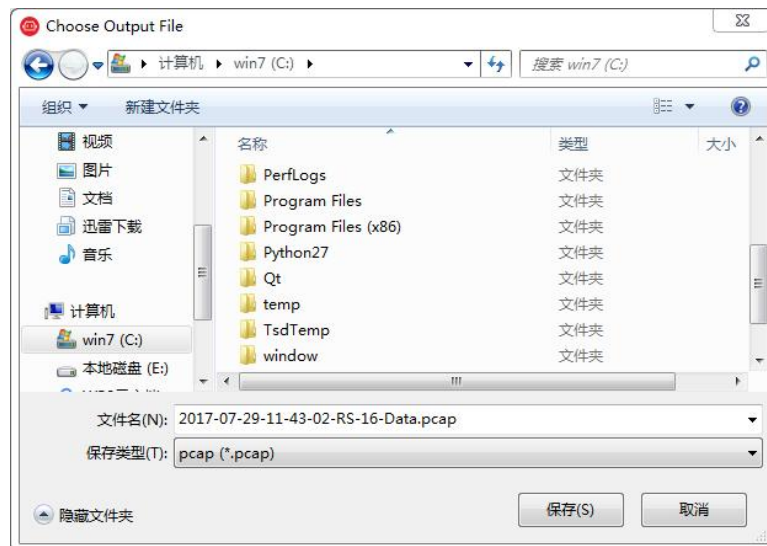

Figure C-5 RSView Record Saving Dialog.

3. Click the **Record** button again to stop saving pcap data.

C.6 Replay PCAP File

You can use RSView to replay or verify the pcap file saved by a RS-Helios LiDAR. You can press the

Play button to play or select frames in the data that you are interested in. You can also use the mouse to select a portion of 3D point cloud which the details will then be tabulated in a spreadsheet for analysis. The saving path of the pcap file should only contain English characters.

1. Click **File > Open** and select **Capture File**

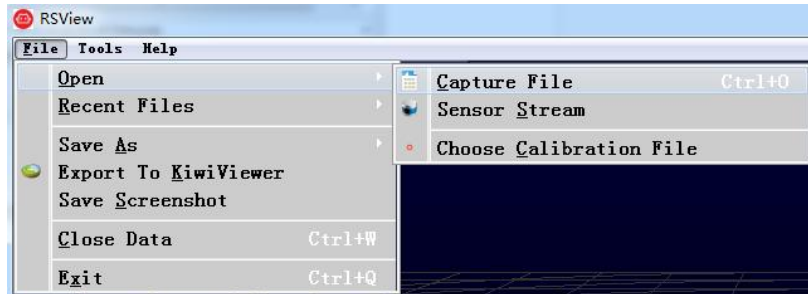

Figure C-6 Open the pcap record file

2. In the pop-up “Open File” dialog, select a recorded pcap file and click **Open (O)**.

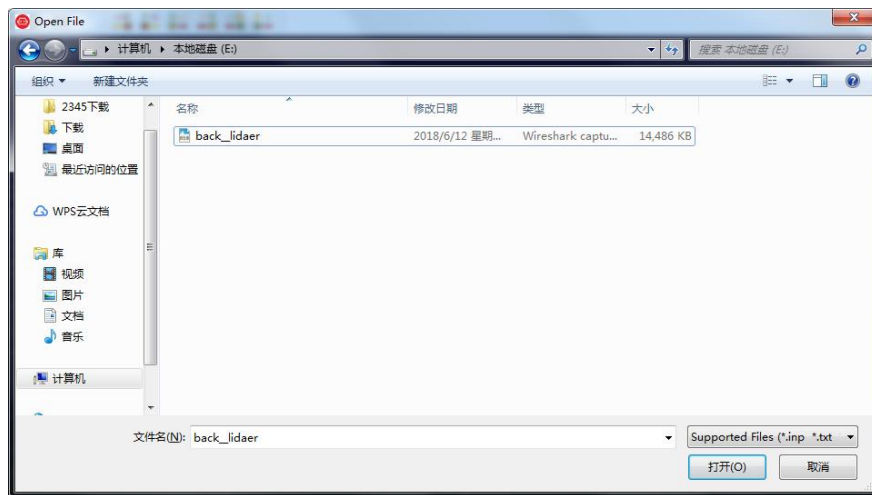

Figure C-7 Open Recorded pcap File

3. In the pop-up “Sensor Configuration” dialog, add and select the correct RS-Helios configuration file and click the **OK** button.

4. Click the **Play** button to play or pause the data. Use the Scrub sliding tool to slide back and forth to select frames at different positions in the data. This tool and the **Record** button are in the same toolbar (Figure C-8)

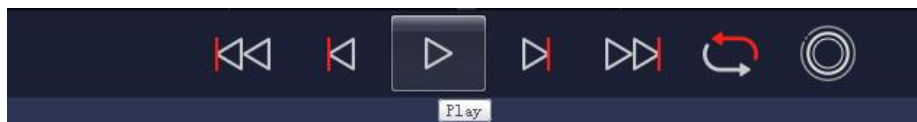

Figure C-8 RSView Play Button and Scrub Tool

5. In order to get a more detailed analysis, select a frame of data that you are interested in and click the **Spreadsheet** button (Figure C-9). A sidebar data table will be displayed on the right side of the screen, which contains details of all the data of this frame



Figure C-9 RSView Spreadsheet Tool.

6. You can adjust the width of each column of the table, or sort to get a better view.

Showing	Data	Attribute: Point Data	Precision: 3	F	Grid	Print	Export	
Point ID	Points	adjustedtime	azimuth	distance_m	intensity	laser_id	timestamp	
0	739	1.776...	998301570.000	993	10.380	5	11	998301570
1	752	1.814...	998301620.000	1011	10.415	6	11	998301620
2	753	1.820...	998301623.000	1012	10.390	25	12	998301623
3	754	1.829...	998301626.000	1013	10.390	13	13	998301626
4	766	1.846...	998301670.000	1029	10.415	6	11	998301670
5	767	1.861...	998301673.000	1030	10.440	25	12	998301673
6	768	1.861...	998301676.000	1031	10.390	13	13	998301676
7	769	1.871...	998301679.000	1032	10.410	33	14	998301679
8	780	1.877...	998301720.000	1047	10.410	6	11	998301720
9	781	1.893...	998301723.000	1048	10.440	25	12	998301723
10	782	1.896...	998301726.000	1049	10.405	13	13	998301726
11	783	1.906...	998301729.000	1050	10.425	40	14	998301729

Figure C-10 RSView Spreadsheet Display

7. Click **Show only selected elements** in Spreadsheet to get the data corresponding to the selected points (Figure C-11).

Showing	Data	Attribute: Point Data	Precision: 3	F	Grid	Print	Export	
Point ID	Points	adjustedtime	azimuth	distance_m	intensity	Show only selected elements.	timestamp	
0	739	1.776...	998301570.000	993	10.380	5	11	998301570
1	752	1.814...	998301620.000	1011	10.415	6	11	998301620

Figure C-11 RSView Show only selected elements Tool

8. Click the **Select All Points** tool, which turns your mouse into a data point selection tool (Figure C-12).

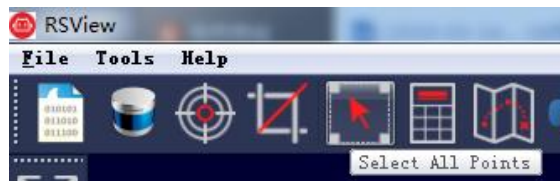

Figure C-12 RSView Select All Points Tool

9. In the 3D rendered data pane, use your mouse to draw a rectangle to frame some data points. The data of these points will immediately populate the data table and the selected data points will turn pink in the data pane (Figure C-13).

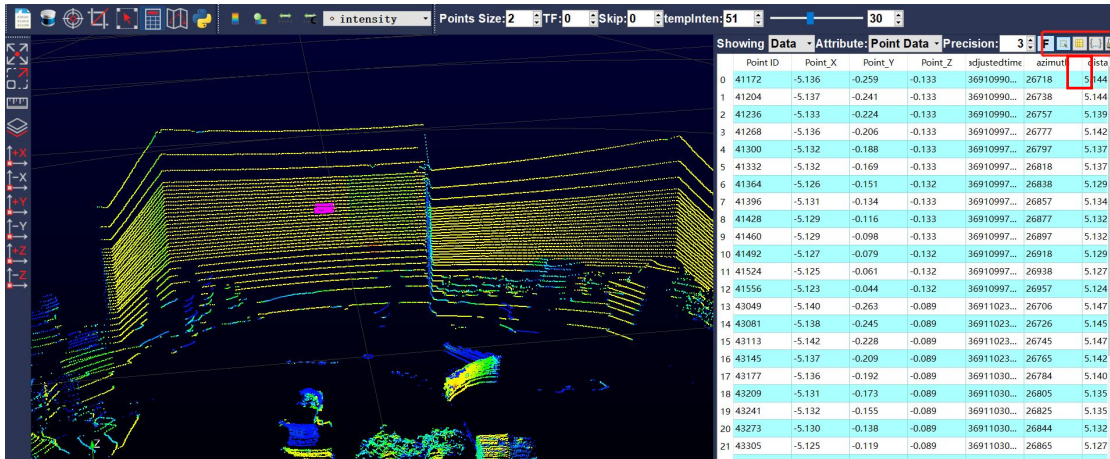

Figure C-13 RSView List Selected Points Tool

10. Any selected points can be saved via **Spreadsheet>Show only selected elements>Output CSV data.**

C.7 Set RSView Data Port

The default MSOP port number of RS-Helios is 6699, and the default DIFOP port number is 7788. If these two port numbers of RS-Helios are modified in the means described in Section C.7 in other ways, you will need to reset the Data Port that RSView acquires data to the modified port number, otherwise there will be no data display. If you don't know the MSOP port number and DIFOP port number of your RS-Helios, you can connect it to the computer and use Wireshark to capture LiDAR packets to view the Data Port information.

Click **Tools> Sensor Network Configuration**, enter the modified RS-Helios MSOP Port and DIFOP Port, and click **Set Data Port**.

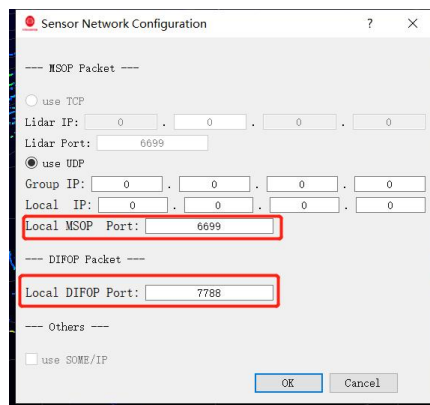

Figure C-14 Sensor Network Configuration

Appendix D RS-Helios ROS&ROS2 Package

This appendix explains how to use Ubuntu+ROS or Ubuntu+ROS2 to acquire and visualize your RS-Helios-1610 data.

D.1 Install Software

1. Download and install Ubuntu 16.04 or Ubuntu18.04 operating system. (ROS2 users are imperative to use the Ubuntu 18.04 system)
2. ROS users: Install and test the basic functions of ROS Kinetic according to the link (<http://wiki.ros.org/kinetic/Installation>). (For Ubuntu 18.04 users, please install ROS-melodic)
ROS2 users: Install and test the basic functions of ROS2 Eloquent according to the link (<https://index.ros.org/doc/ros2/Installation/Eloquent/>).
3. Download and install [libpcap-dev](#).

D.2 Download & Compile RoboSense LiDAR Driver Package

You can get the latest LiDAR driver package from

https://github.com/RoboSense-LiDAR/rslidar_sdk , or contact our technical support to get it.

After downloading, please read the **README** file in the driver package carefully, which describes in detail how to compile and use the LiDAR driver package.

rslidar_sdk is our latest LiDAR driver package, which has included drivers for five mechanical LiDAR sensors: RS-16, RS-32, RS-BP, RS-Ruby, RS-Helios. Three compilation modes are supported:

1. Direct Compilation

The user enters the main directory of the rslidar_sdk driver package and creates a build folder to compile and run.

```
mkdir build
cd build
cmake .. && make
./rslidar_sdk_node
```

2. Compilation in ROS

Create ros working directory:

```
cd ~
mkdir -p catkin_ws/src
```

2. Copy the rslidar_sdk driver package to the ROS working directory ~/catkin_ws/src. Open the CMakeLists.txt file in the rslidar_sdk driver package, and change the set (COMPILE_METHOD ORIGINAL) at the top of the file to set (COMPILE_METHOD CATKIN). At the same time, rename the package_ros1.xml file in the driver package to package.xml.

Run the following command in the terminal to compile:

```
cd ~/catkin_ws  
catkin_make
```

3. Compilation in ROS2

Create ros2 working directory:

```
cd ~  
mkdir -p catkin_ws/src
```

Copy the rslidar_sdk driver package to the ROS2 working directory ~/catkin_ws/src. Open the CMakeLists.txt file in the rslidar_sdk driver package, and change the set (COMPILE_METHOD ORIGINAL) at the top of the file to set (COMPILE_METHOD COLCON). At the same time, rename the package_ros2.xml file in the driver package to package.xml.

Run the following command in the terminal to compile:

```
cd ~/catkin_ws  
colcon build
```

D.3 Configure PC IP

In the default RS-Helios firmware, configure the static IP address of the computer to "192.168.1.102", the subnet mask to "255.255.255.0". The gateway does not need to be configured.

After the configuration is completed, you can use the ifconfig command to check whether the static IP takes effect.

D.4 Real Time Display

There are detailed documents in the rslidar_sdk project to guide how to display the point cloud in real time in the ROS or ROS2 environment. Here is a brief introduction, taking the ROS environment as an example.

1. Connect RS-Helios to computer with a network cable, power it on and run, and wait for the computer to recognize the LiDAR.
2. Run the launch file provided in the rslidar_sdk driver package to start the node program that displays data in real time. The launch file is located in rslidar_sdk/launch/start.launch. Open a terminal and run:

```
cd ~/catkin_ws  
source devel/setup.bash  
roslaunch rslidar_sdk start.launch
```

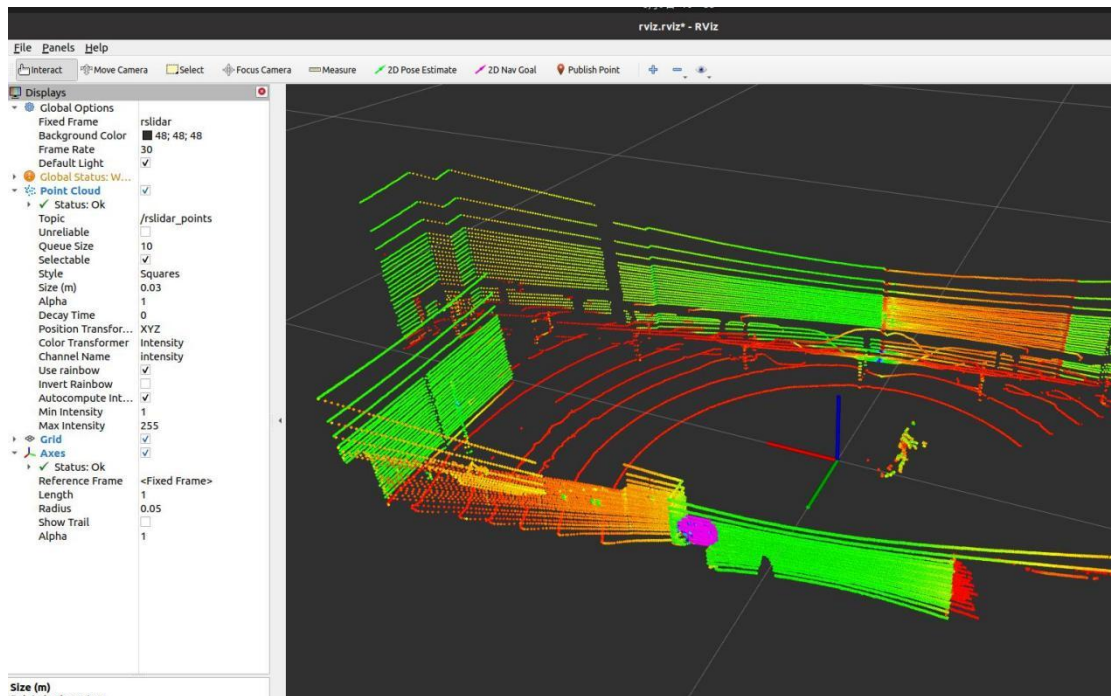



Figure D-1 rviz displays RS-Helios point cloud data

D.5 View Offline Data

About how to parse data offline (rosviz or pcap), there is also a detailed introduction in the documentation in the rslidar_sdk driver package. Here is just a brief introduction, taking pcap as an example. You can use rslidar_sdk to parse the saved offline pcap file into point cloud data for display.

1. Modify the parameters in rslidar_sdk/config/config.yaml

msg_source: modified to 3

pcap_directory: configure to the absolute path of the pcap file:

(e.g. /home/robosense/RSHelios.pcap)

2. Open the terminal and run the node program:

```
cd ~/catkin_ws
source devel/setup.bash
roslaunch rslidar_sdk start.launch
```

Appendix F Sensor Cleaning

In order to be able to accurately sense the surrounding environment, LiDAR needs to be kept clean, especially the optical ring lens.

F.1 Attention

Please read the contents of this appendix F carefully and completely before cleaning your LiDAR, otherwise improper operation may damage the sensor. When the LiDAR is used in a harsh environment, it is necessary to clean up the dirt on the surface in time to keep the LiDAR clean, otherwise it will affect the normal use of the LiDAR

F.2 Required Materials

1. Clean fiber cloth
2. Spray with neutral warm soap
3. Spray with clean water
4. Isopropanol solvent
5. Clean gloves

F.3 Cleaning Method

If there is only some dust adhered to the surface of the sensor, you can directly dip a small amount of isopropanol solution with a clean fiber cloth, and then gently wipe the LiDAR surface to clean, and then wipe it dry with a clean fiber cloth.

If the surface of the LiDAR is caked with mud or dirt, first spray clean water on the surface of the dirty part to remove the mud or the dirt (Note: Do not try to wipe off the mud directly with a fiber cloth, as this may scratch the surface, especially the optical ring lens.). Secondly, spray warm soapy water on the dirty parts (The lubricating effect of soapy water can accelerate the detachment of the dirt). Gently wipe the surface of the sensor with the fiber cloth again, be careful not to scratch the surface. Finally, clean the soap residue on the surface with clean water (If there are still residues on the surface, use an isopropyl alcohol solution to clean it again), and wipe it dry with a clean microfiber cloth.



robosense

www.robosense.ai

Suteng Innovation Technology Co., Ltd.

RoboSense Global Headquarters - Building 9, Block 2, Zhongguan Honghualing Industry Southern District,
1213 Liuxian Avenue, Taoyuan Street, Nanshan District, Shenzhen, China



Q RoboSense LiDAR